

A Series – Bare Tube Bundle Shell & Tube Water to Oil Cooling

The A/SA Series is very versatile in its ability to accommodate multiple application requirements. 600 and 800 sizes offer 1/4" tube and 1000, 1200, and 1600 sizes feature 3/8" tube.

A series is a non-ferrous, Brass construction, which makes it ideal for water to water, including sea water cooling applications.

The SA series is a competitively priced steel construction version of the A series, and mainly used for standard hydraulic applications. Steel/cast iron components offer a lower cost solution. SA is only available in 1200 and 1600 sizes.

The A Series is a legacy product developed to interchange with ITT/Standard X-Change.

TTP's XSelector® sizing program can be used to help optimize the sizing of the cooler for better performance and value.



Options
 Non-ferrous construction (water-to-water service)
 90/10 copper nickel cooling tubes, bronze end bonnets for sea water service and zinc anodes

How to Order

Model Series

Model Size Selected

Baffle Spacing

Tube Diameter Code

Tubeside

Shell Material

Cooling Tube Material

End Bonnet Material

Zinc Anodes

A Series - Brass
A - NPT Shell side connections; NPT Tube side connections
AS - SAE O-Ring Shell side connections; NPT Tube side connections
AM - BSPP Shell side connections; BSPP Tube side connections
AF - SAE 4 Bolt Flange (with UNC threads) Shell side connections; NPT Tube side connections
AFM - SAE 4 Bolt Flange (with Metric threads) Shell side connections; BSPP Tube side connections
SAE flanges available on some models. Consult factory for details.

SA Series - Steel (1200 & 1600 models only)
SA - NPT Shell Side connections x NPT Tube Side connections
SAF - SAE Flange (with UNC threads) Shell Side connections x NPT Tube Side connections

608, 614, 624, 814, 824, 836, 1014, 1024, 1036, 1224, 1236, 1248, 1260, 1624, 1636, 1648, 1660, 1672
 (See Performance Curve Chart on page 3 for sizes)

1, 1.5, 2, 3, 4, 6
 (See Performance Curve Chart on page 3 for options)

4 - 1/4" (600 & 800 Sizes only)
6 - 3/8" (1000, 1200 & 1600 Sizes only)

0 - One Pass
T - Two Pass
F - Four Pass

Blank - Steel (SA Series Only)
BR - Brass

Blank - Copper
CN - Copper Nickel

Blank - Cast Iron
B - Bronze (A Series Only)

Blank - None
Z - Zinc

Features

- ITT Interchange**
- B or HC Series is Recommended for New Applications**
- Sea Water Applications (A Series Only), End Model Code with BR-CN-B-Z**
- Water to Water Applications (A Series Only)**
- Cooling Tube Side Material Options**
 - Standard Steel
 - Copper Nickel
 - Bronze
- Multiple Connection Options (shell x tube)**
 - NPT x NPT
 - SAE x NPT
 - Sae Code 61 x NPT
 - BSPP x BSP
- End Bonnets Removable for Servicing**
- Mounting Feet Included (May be Rotated in 90° Increments)**

Ratings

- Maximum Operating Pressure**
 - Shell Side 300 PSI
 - Tube Side 150 PSI
- Maximum Operating Temperature** 300°F
- Heat Rejection from** 2-350 HP
- Oil Flow from** 3-200 GPM

Materials

- Shell** Steel/Brass
- End Bonnets** Cast Iron/Bronze
- Tubes** Copper/Copper Nickel
- Mounting Brackets** Steel
- Hubs & Tubesheets** Steel/Brass
- Gaskets** Nitrile Rubber/Cellulose Fiber
- Baffles** Brass
- Nameplate** Aluminum Foil

Piping Diagram

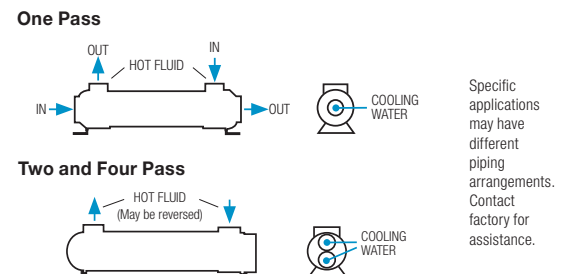

* To register for XSelector® please go to www.thermaltransfer.com/get-in-touch/ and complete the XSelector® Inquiry form and submit. Download the XSelector® for both Apple and Android formats by searching for XSelector® in their App Stores. You must first register for XSelector® before using it on mobile devices.

Selection Procedure

Performance Curves are based on 100SSU oil leaving the cooler 40°F higher than the water temperature used for cooling. This is also referred to as a 40°F approach temperature. Curves are based on a 2:1 oil to water flow ratio.

STEP 1 Determine the Heat Load. This will vary with different systems, but typically coolers are sized to remove 25 to 50% of the input nameplate horsepower. (Example: 100 HP Power Unit x .33 = 33 HP Heat load.)

$$\text{If BTU/HR is known: } \text{HP} = \frac{\text{BTU/HR}}{2545}$$

STEP 1 Determine Approach Temperature. Desired oil leaving cooler °F – Water Inlet temp. °F = Actual Approach (Max. reservoir temp.)

STEP 1 Determine Curve Horsepower Heat Load. Enter the information from above:

$$\text{Horsepower heat load} \times \frac{40}{\text{Actual Approach}} \times \text{Viscosity Correction A} = \text{Curve Horsepower}$$

STEP 1 Enter curves at oil flow through cooler and curve horsepower. Any curve above the intersecting point will work.

STEP 1 Determine Oil Pressure Drop from Curves:
 ● = 5 PSI ■ = 10 PSI ▲ = 20 PSI Multiply pressure drop from curve by correction factor B found on oil viscosity correction curve.

Oil Temperature

Oil coolers can be selected using entering or leaving oil temperatures.

Typical operating temperature ranges are:

Hydraulic Oil	110°F - 130°F
Hydrostatic Drive Oil	130°F - 180°F
Bearing Lube Oil	120°F - 160°F
Lube Oil Circuits	110°F - 130°F

Desired Reservoir Temperature

Return Line Cooling: Desired temperature is the oil temperature leaving the cooler. This will be the same temperature that will be found in the reservoir.

Off-Line Recirculation Cooling Loop: Desired temperature is the oil temperature entering the cooler. In this case, the oil temperature change must be determined so that the actual oil leaving temperature can be found. Calculate the oil temperature change (oil ΔT) with this formula:

$$\text{Oil } \Delta T = (\text{BTUs/HR}) / (\text{GPM Oil Flow} \times 210).$$

To calculate the oil leaving temperature from the cooler, use this formula:

$$\text{Oil Leaving Temp.} = \text{Oil Entering Temp.} - \text{Oil } \Delta T.$$

This formula may also be used in any application where the only temperature available is the entering oil temperature.

Oil Pressure Drop: Most systems can tolerate a pressure drop through the heat exchanger of 20 to 30 PSI. Excessive pressure drop should be avoided. Care should be taken to limit pressure drop to 5 PSI or less for case drain applications where high back pressure may damage the pump shaft seals.

Viscosity Correction

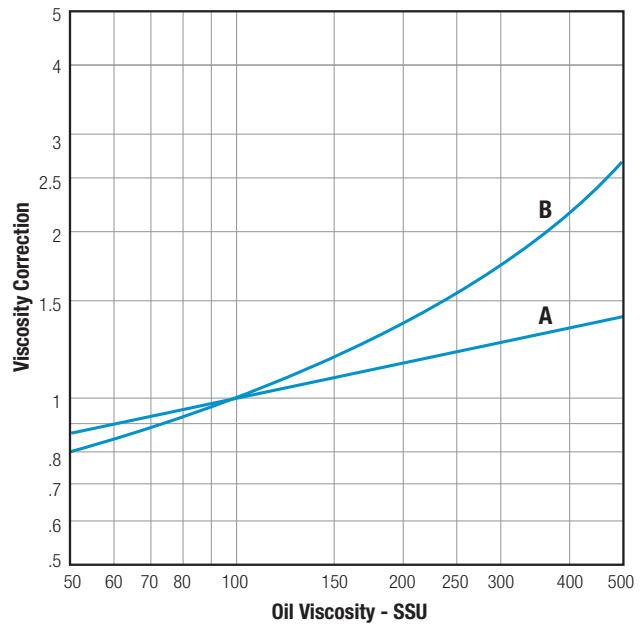

Maximum Flow Rates

Example Model No.

A - 1024 - 2 - 6 - F

Unit Size	Baffle Spacing	Shell Side (GPM)	Tube Side (GPM)		
			O	T	F
608	1, 2	14, 29	48	24	12
614	1.5, 4	21, 29	48	24	12
624	2, 4	29	48	24	12
814	1.5, 3	29, 57	87	44	22
824 & 836	2, 4	38, 69	87	44	22
1014	1.5, 3	32, 64	146	73	37
1024 & 1036	2, 4	42, 69	146	73	37
1224	2, 4	51, 103	224	112	56
1236 & 1248	3, 6	77, 115	224	112	56
1260	4, 6	103, 115	224	112	56
1624	2, 6	66, 200	280	140	70
1636 & 1648	3, 6	100, 200	280	140	70
1660 & 1672	4, 6	133, 200	280	140	70

Caution: Incorrect installation can cause this product to fail prematurely, causing the shell side and tube side fluids to intermix.

Performance Curves

For additional sizing information consider using TTP's **XSelector®** online sizing Program.*

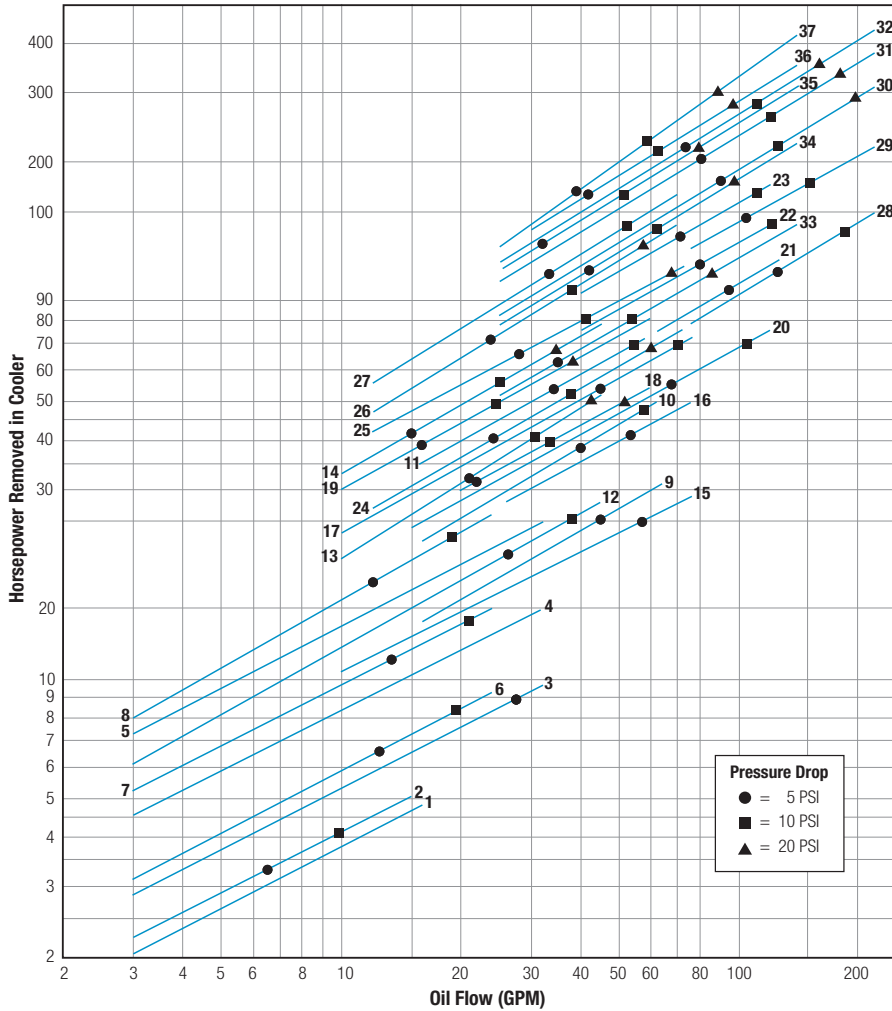

Curve Number	Model	Shipping Weight (LBS)
3	A-608-2-4-F	12
4	A-614-4-4-F	17
5	A-624-4-4-F	20
6	A-608-1-4-F	12
7	A-614-1.5-4-F	17
8	A-624-2-4-F	20
9	A-814-3-4-F	40
10	A-824-4-4-F	50
11	A-836-4-4-F	58
12	A-814-1.5-4-F	40
13	A-824-2-4-F	50
14	A-836-2-4-F	58
15	A-1014-3-6-F	49
16	A-1024-4-6-F	63
17	A-1036-4-6-F	72
18	A-1024-2-6-F	63
19	A-1036-2-6-F	72
20	A-1224-4-6-F	78
21	A-1236-6-6-F	118
22	A-1248-6-6-F	143
23	A-1260-6-6-F	165
24	A-1224-2-6-F	78
25	A-1236-3-6-F	118
26	A-1248-3-6-F	143
27	A-1260-4-6-F	165
28	A-1624-6-6-F	180
29	A-1636-6-6-F	210
30	A-1648-6-6-F	250
31	A-1660-6-6-F	286
32	A-1672-6-6-F	330
33	A-1624-2-6-F	180
34	A-1636-3-6-F	210
35	A-1648-3-6-F	250
36	A-1660-4-6-F	286
37	A-1672-4-6-F	330

Shipping weights are approximate.

* To register for **XSelector®** please go to www.thermaltransfer.com/get-in-touch/ and complete the **XSelector®** Inquiry form and submit. Download the **XSelector®** for both Apple and Android formats by searching for **XSelector®** in their App Stores. You must first register for **XSelector®** before using it on mobile devices.

Dimensions

One Pass

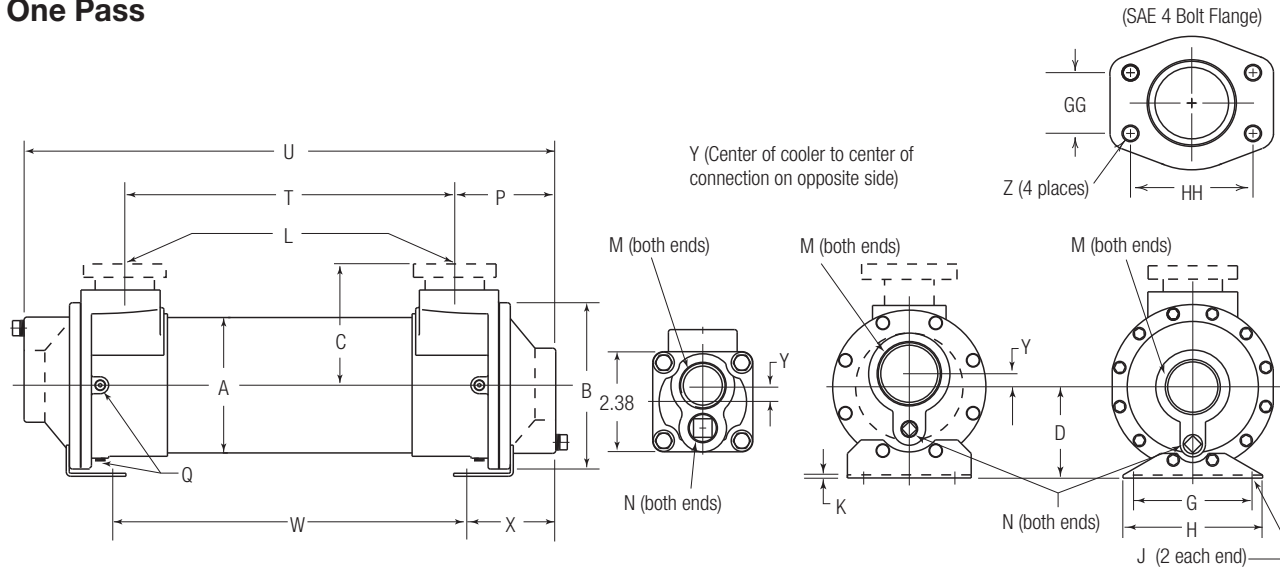

**A-600
A-800 Series**

**A-1000, A-1200
A-1600 Series**

Flange Size	GG	HH	Z - CF	Z - CFM
1	1.03	2.06	3/8-16 UNC	M-10
1.50	1.41	2.75	1/2-13 UNC	M-12
2	1.69	3.06	1/2-13 UNC	M-12
3	2.44	4.19	5/8-11 UNC	M-16

Model	A Dia.	B Dia.	C		D	G	H	J	K	L		M NPT	N NPT	P	Q NPT	T	U	W	X	Y
			NPT/BSPP SAE O-Ring	SAE 4 Bolt Flange						NPT/BSPP Flange	SAE O-Ring									
A-608	3.12	4.19	2.44	C/F	2.44	2.50	3.50	.38 x .88	.12	1.00	1.50	.38	2.56	(2) .25	6.12	11.25	5.47	3.06	.38	
A-614	3.12	4.19	2.44	C/F	2.44	2.50	3.50	.38 x .88	.12	1.00	1 1/4-12 UNF-2B	1.50	.38	2.56	(2) .25	12.12	17.25	11.47	3.06	.38
A-624	3.12	4.19	2.44	C/F	2.44	2.50	3.50	.38 x .88	.12	1.00		1.50	.38	2.56	(2) .25	22.12	27.25	21.47	3.06	.38
A-814	4.12	5.88	3.12	C/F	3.50	3.50	4.75	.50 x 1.62	.12	1.50	#24, 1 1/8-12 UN-2B	2.00	.38	3.44	(6) .38	11.12	18.00	12.88	2.56	.50
A-824	4.12	5.88	3.12	C/F	3.50	3.50	4.75	.50 x 1.62	.12	1.50		2.00	.38	3.44	(6) .38	21.12	28.00	22.88	2.56	.50
A-836	4.12	5.88	3.12	C/F	3.50	3.50	4.75	.50 x 1.62	.12	1.50	#24, 1 1/8-12 UN-2B	2.00	.38	3.44	(6) .38	33.12	40.00	34.88	2.56	.50
A-1014	5.12	6.50	3.62	4.34	3.50	4.00	5.00	.44 x 2.20	.12	1.50		2.50	.38	3.69	(6) .25	11.12	18.50	11.75	3.38	.50
A-1024	5.12	6.50	3.62	4.34	3.50	4.00	5.00	.44 x 2.20	.12	1.50	#24, 1 1/8-12 UN-2B	2.50	.38	3.69	(6) .25	21.12	28.50	21.75	3.38	.50
A-1036	5.12	6.50	3.62	4.34	3.50	4.00	5.00	.44 x 2.20	.12	1.50		2.50	.38	3.69	(6) .25	33.12	40.50	33.75	3.38	.50
A-1224	6.12	7.50	4.25	4.84"	4.12	5.00	6.00	.50 x .88	.12	2.00	#32, 2 1/2-12 UN-2B	3.00	.50	4.25	(6) .25	20.50	29.00	21.50	3.75	.50
A-1236	6.12	7.50	4.25	4.84"	4.12	5.00	6.00	.50 x .88	.12	2.00		3.00	.50	4.25	(6) .25	32.50	41.00	33.50	3.75	.50
A-1248	6.12	7.50	4.25	4.84"	4.12	5.00	6.00	.50 x .88	.12	2.00	#32, 2 1/2-12 UN-2B	3.00	.50	4.25	(6) .25	44.50	53.00	45.50	3.75	.50
A-1260	6.12	7.50	4.25	4.84"	4.12	5.00	6.00	.50 x .88	.12	2.00		3.00	.50	4.25	(6) .25	56.50	65.00	57.50	3.75	.50
A-1624	8.00	9.75	5.62	6.12"	5.38	7.00	8.25	.62 x 1.12	.19	3.00	—	3.00	.50	6.00	(6) .25	19.00	31.00	20.50	5.25	.50
A-1636	8.00	9.75	5.62	6.12"	5.38	7.00	8.25	.62 x 1.12	.19	3.00	—	3.00	.50	6.00	(6) .25	31.00	43.00	44.50	5.25	.50
A-1648	8.00	9.75	5.62	6.12"	5.38	7.00	8.25	.62 x 1.12	.19	3.00	—	3.00	.50	6.00	(6) .25	43.00	55.00	44.50	5.25	.50
A-1660	8.00	9.75	5.62	6.12"	5.38	7.00	8.25	.62 x 1.12	.19	3.00	—	3.00	.50	6.00	(6) .25	55.00	67.00	56.50	5.25	.50
A-1672	8.00	9.75	5.62	6.12"	5.38	7.00	8.25	.62 x 1.12	.19	3.00	—	3.00	.50	6.00	(6) .25	67.00	79.00	68.50	5.25	.50

SAF-1200 5.88. *SAF-1600 7.38.

NOTE: We reserve the right to make reasonable design changes without notice. Consult factory. All dimensions are inches.

Dimensions

Two Pass

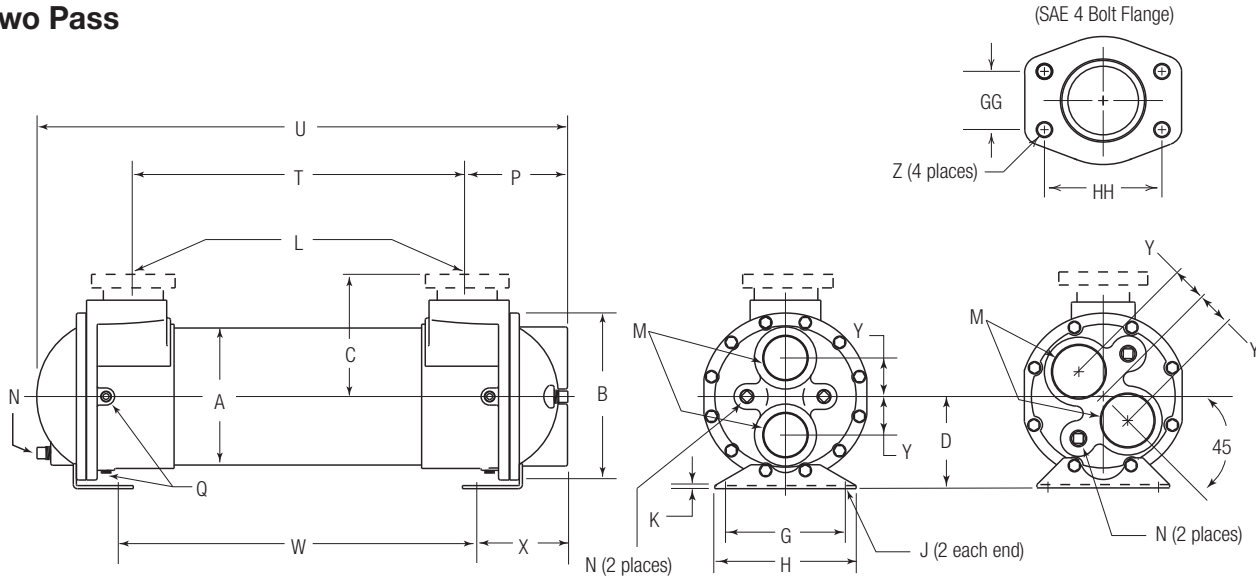

**A-600, A-800, A-1000
A-1600 Series**

A-1200 Series

Flange Size	GG	HH	Z - CF	Z - CFM
1	1.03	2.06	3/8-16 UNC	M-10
1.50	1.41	2.75	1/2-13 UNC	M-12
2	1.69	3.06	1/2-13 UNC	M-12
3	2.44	4.19	5/8-11 UNC	M-16

Model	A Dia.	B Dia.	C		D	G	H	J	K	L		M NPT	N NPT	P	Q NPT	T	U	W	X	Y
			NPT/BSPP SAE O-Ring	SAE 4 Bolt Flange						NPT/BSPP Flange	SAE O-Ring									
A-608	3.12	4.19	2.44	C/F	2.44	2.50	3.50	.38 x .88	.12	1.00	1.00	.38	2.44	(2) .25	6.12	10.75	5.47	2.94	1.00	
A-614	3.12	4.19	2.44	C/F	2.44	2.50	3.50	.38 x .88	.12	1.00	1.00	.38	2.44	(2) .25	12.12	16.75	11.47	2.94	1.00	
A-624	3.12	4.19	2.44	C/F	2.44	2.50	3.50	.38 x .88	.12	1.00	1.00	.38	2.44	(2) .25	22.12	26.75	21.47	2.94	1.00	
A-814	4.12	5.88	3.12	C/F	3.50	3.50	4.75	.50 x 1.62	.12	1.50	1.25	.38	3.44	(6) .38	11.12	17.62	12.88	2.56	1.19	
A-824	4.12	5.88	3.12	C/F	3.50	3.50	4.75	.50 x 1.62	.12	1.50	1.25	.38	3.44	(6) .38	21.12	27.62	22.88	2.56	1.19	
A-836	4.12	5.88	3.12	C/F	3.50	3.50	4.75	.50 x 1.62	.12	1.50	1.25	.38	3.44	(6) .38	33.12	39.62	34.88	2.56	1.19	
A-1014	5.12	6.50	3.62	4.34	3.50	4.00	5.00	.44 x 2.20	.12	1.50	1.50	.38	3.69	(6) .25	11.12	18.31	11.75	3.38	1.50	
A-1024	5.12	6.50	3.62	4.34	3.50	4.00	5.00	.44 x 2.20	.12	1.50	1.50	.38	3.69	(6) .25	21.12	28.31	21.75	3.38	1.50	
A-1036	5.12	6.50	3.62	4.34	3.50	4.00	5.00	.44 x 2.20	.12	1.50	1.50	.38	3.69	(6) .25	33.12	40.31	33.75	3.38	1.50	
A-1224	6.12	7.50	4.25	4.84	4.12	5.00	6.00	.50 x .88	.12	2.00	2.00	.50	4.25	(6) .25	20.50	28.75	21.50	3.75	1.56	
A-1236	6.12	7.50	4.25	4.84	4.12	5.00	6.00	.50 x .88	.12	2.00	2.00	.50	4.25	(6) .25	32.50	40.75	33.50	3.75	1.56	
A-1248	6.12	7.50	4.25	4.84	4.12	5.00	6.00	.50 x .88	.12	2.00	2.00	.50	4.25	(6) .25	44.50	52.75	45.50	3.75	1.56	
A-1260	6.12	7.50	4.25	4.84	4.12	5.00	6.00	.50 x .88	.12	2.00	2.00	.50	4.25	(6) .25	56.50	64.75	57.50	3.75	1.56	
A-1624	8.00	9.75	5.62	6.12	5.38	7.00	8.25	.62 x 1.12	.19	3.00	—	2.50	.50	6.00	(6) .25	19.00	30.50	20.50	5.25	2.25
A-1636	8.00	9.75	5.62	6.12	5.38	7.00	8.25	.62 x 1.12	.19	3.00	—	2.50	.50	6.00	(6) .25	31.00	42.50	44.50	5.25	2.25
A-1648	8.00	9.75	5.62	6.12	5.38	7.00	8.25	.62 x 1.12	.19	3.00	—	2.50	.50	6.00	(6) .25	43.00	54.50	44.50	5.25	2.25
A-1660	8.00	9.75	5.62	6.12	5.38	7.00	8.25	.62 x 1.12	.19	3.00	—	2.50	.50	6.00	(6) .25	55.00	66.50	56.50	5.25	2.25
A-1672	8.00	9.75	5.62	6.12	5.38	7.00	8.25	.62 x 1.12	.19	3.00	—	2.50	.50	6.00	(6) .25	67.00	78.50	68.50	5.25	2.25

*SAF-1200 5.88. **SAF-1600 7.38.

NOTE: We reserve the right to make reasonable design changes without notice. Consult factory. All dimensions are inches.

Dimensions

Four Pass

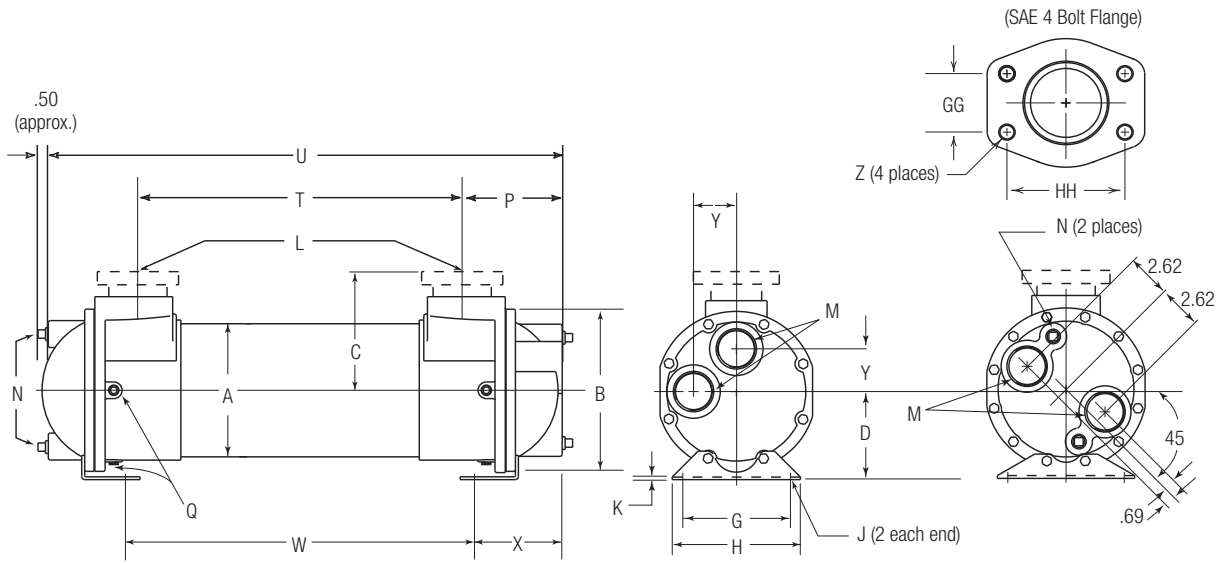

**A-600, A-800, A-1000
A-1200 Series**

A-1600 Series

Flange Size	GG	HH	Z - CF	Z - CFM
1	1.03	2.06	3/8-16 UNC	M-10
1.50	1.41	2.75	1/2-13 UNC	M-12
2	1.69	3.06	1/2-13 UNC	M-12
3	2.44	4.19	5/8-11 UNC	M-16

Model	A Dia.	B Dia.	C		D	G	H	J	K	L		M NPT	N NPT	P	Q NPT	T	U	W	X	Y
			NPT/BSPP SAE O-Ring	SAE 4 Bolt Flange						NPT/BSPP Flange	SAE O-Ring									
A-608	3.12	4.19	2.44	C/F	2.44	2.50	3.50	.38 x .88	.12	1.00	#16,	.75	.38	2.31	(2) .25	6.12	10.88	5.47	2.81	1.00
A-614	3.12	4.19	2.44	C/F	2.44	2.50	3.50	.38 x .88	.12	1.00	1 1/8-12	.75	.38	2.31	(2) .25	12.12	16.88	11.47	2.81	1.00
A-624	3.12	4.19	2.44	C/F	2.44	2.50	3.50	.38 x .88	.12	1.00	UNF-2b	.75	.38	2.31	(2) .25	22.12	26.88	21.47	2.81	1.00
A-814	4.12	5.88	3.12	C/F	3.50	3.50	4.75	.50 x 1.62	.12	1.50	#24, 1 1/8-12 UN-2B	.75	.38	3.44	(6) .38	11.12	17.62	12.88	2.56	1.06
A-824	4.12	5.88	3.12	C/F	3.50	3.50	4.75	.50 x 1.62	.12	1.50		.75	.38	3.44	(6) .38	21.12	27.62	22.88	2.56	1.06
A-836	4.12	5.88	3.12	C/F	3.50	3.50	4.75	.50 x 1.62	.12	1.50		.75	.38	3.44	(6) .38	33.12	39.62	34.88	2.56	1.06
A-1014	5.12	6.50	3.62	4.34	3.50	4.00	5.00	.44 x 2.20	.12	1.50		1.00	.38	3.56	(6) .25	11.12	18.38	11.75	3.25	1.69
A-1024	5.12	6.50	3.62	4.34	3.50	4.00	5.00	.44 x 2.20	.12	1.50	#32, 2 1/2-12 UN-2B	1.00	.38	3.56	(6) .25	21.12	28.38	21.75	3.25	1.69
A-1036	5.12	6.50	3.62	4.34	3.50	4.00	5.00	.44 x 2.20	.12	1.50		1.00	.38	3.56	(6) .25	33.12	40.38	33.75	3.25	1.69
A-1224	6.12	7.50	4.25	4.84"	4.12	5.00	6.00	.50 x .88	.12	2.00	#32, 2 1/2-12 UN-2B	1.50	.50	4.25	(6) .25	20.50	29.00	21.50	3.75	2.00
A-1236	6.12	7.50	4.25	4.84"	4.12	5.00	6.00	.50 x .88	.12	2.00		1.50	.50	4.25	(6) .25	32.50	41.00	33.50	3.75	2.00
A-1248	6.12	7.50	4.25	4.84"	4.12	5.00	6.00	.50 x .88	.12	2.00		1.50	.50	4.25	(6) .25	44.50	53.00	45.50	3.75	2.00
A-1260	6.12	7.50	4.25	4.84"	4.12	5.00	6.00	.50 x .88	.12	2.00		1.50	.50	4.25	(6) .25	56.50	65.00	57.50	3.75	2.00
A-1624	8.00	9.75	5.62	6.12"	5.38	7.00	8.25	.62 x 1.12	.19	3.00	—	2.00	.50	6.00	(6) .25	19.00	30.75	20.50	5.25	—
A-1636	8.00	9.75	5.62	6.12"	5.38	7.00	8.25	.62 x 1.12	.19	3.00	—	2.00	.50	6.00	(6) .25	31.00	42.75	44.50	5.25	—
A-1648	8.00	9.75	5.62	6.12"	5.38	7.00	8.25	.62 x 1.12	.19	3.00	—	2.00	.50	6.00	(6) .25	43.00	54.75	44.50	5.25	—
A-1660	8.00	9.75	5.62	6.12"	5.38	7.00	8.25	.62 x 1.12	.19	3.00	—	2.00	.50	6.00	(6) .25	55.00	66.75	56.50	5.25	—
A-1672	8.00	9.75	5.62	6.12"	5.38	7.00	8.25	.62 x 1.12	.19	3.00	—	2.50	.50	6.00	(6) .25	67.00	78.75	68.50	5.25	—

*SAF-1200 5.88. **SAF-1600 7.38.

NOTE: We reserve the right to make reasonable design changes without notice. Consult factory. All dimensions are inches.



HydroThrift Corporation

1301 Sanders Ave SW

Massillon, OH 44647 USA

sales@hydrothrift.com 330-837-5141