

# AOVH Series – Industrial Air Cooled Copper Tube/Aluminum Fins

The Industrial AOVH Series is a high performance version of the AO Series that features high flow rates and higher heat rejection in a compact size. The series design includes a double core, high performance fan and adjustable louvers that allow the user to regulate the direction of heated exhaust air. The utilization of High-Low Turbulator design yields high flow capacity with low flow pressure drop.

TTP's XSelector® sizing program can be used to help optimize the sizing of the cooler for better performance and value.

- High performance AO
- High flow rates
- Adjustable louvers (manual)
- Compact
- One or two pass

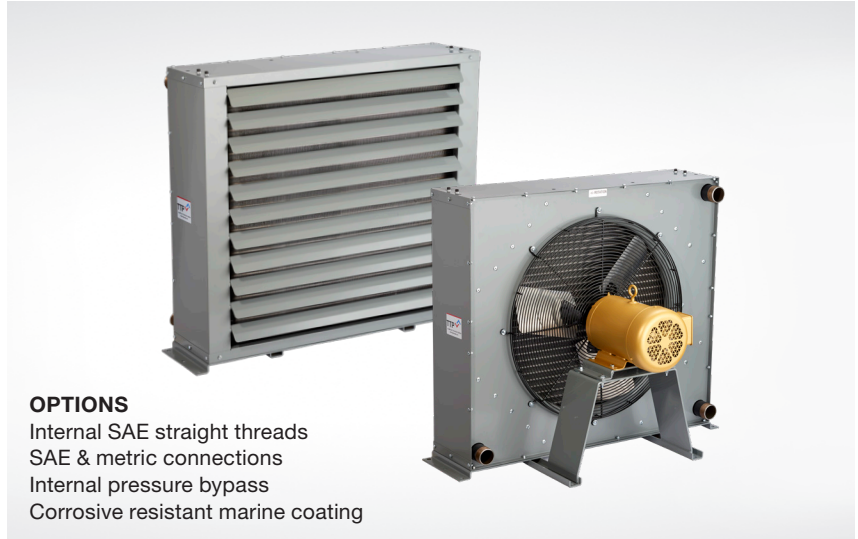

**OPTIONS**  
 Internal SAE straight threads  
 SAE & metric connections  
 Internal pressure bypass  
 Corrosive resistant marine coating

## How to Order

**Model Series**  
 **AOVH**  
**AOVHR** - With Bypass

**Model Size Selected**  
 **5, 10, 15, 20, 25, 30, 35, 40**  
 (See Performance Curve Chart on page 2 for sizes)

**Number of Passes\***  
 **Blank** - No Bypass  
**2** - Two Pass\*  
**\*ADD FOR AOVHR MODELS ONLY:** 2 pass only on AOVHR series

**Connection Type**  
 **Blank** - NPT  
**S** - SAE  
**M** - BSPP

**Bypass Setting\***  
 **Blank** - No Bypass  
**30** -30 PSI  
**60** - 60 PSI  
**\* ADD FOR AOVHR MODELS ONLY**  
 This is a partial flow pressure bypass only. It is not designed to be a full flow system bypass.

**Motor**  
 **1 PH** - 115/230 Volt  
**1 PH EXP** - 115/230 Volt Explosion Proof  
**3 PH** - 208-230/460  
**3 PH EXP** - 208-230/460 Volt Explosion Proof  
**575** - 575 Volt  
**NM** - No Motor

## Two Pass (Low to Medium Oil Flows)

Model	Flow GPM (USA)
AOVHR-5-2	4-50
AOVHR-10-2	4-60
AOVHR-15-2	4-60
AOVHR-20-2	4-80
AOVHR-25-2	4-80
AOVHR-30-2	4-80
AOVHR-35-2	6-80
AOVHR-40-2	8-80

## Ratings

**Maximum Operating Pressure**  
 300 PSI

**Maximum Operating Temperature**  
 400°F

## Materials

- Tubes** Copper
- Fins** Aluminum
- Turbulators** Steel
- Fan Blade** Aluminum with steel hub
- Fan Guard** Zinc plated steel
- Cabinet** Steel with powder coat finish
- Manifolds** Steel
- Connections** Steel

## Piping Diagram

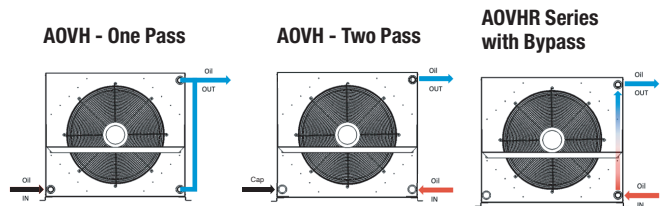

\* **ADD FOR AOVHR MODELS ONLY:** Bypass setting & number of passes. Only available in Two Pass. This is a partial flow pressure bypass only. It is not designed to be a full flow system bypass.  
 \* To register for XSelector® please go to [www.thermaltransfer.com/get-in-touch/](http://www.thermaltransfer.com/get-in-touch/) and complete the XSelector® Inquiry form and submit.  
 Download the XSelector® for both Apple and Android formats by searching for XSelector® in their App Stores. You must first register for XSelector® before using it on mobile devices.

For additional sizing information consider using TTP's **XSelector®** online sizing Program.\*

## Performance Curves

### One Pass Oil (AOVH)

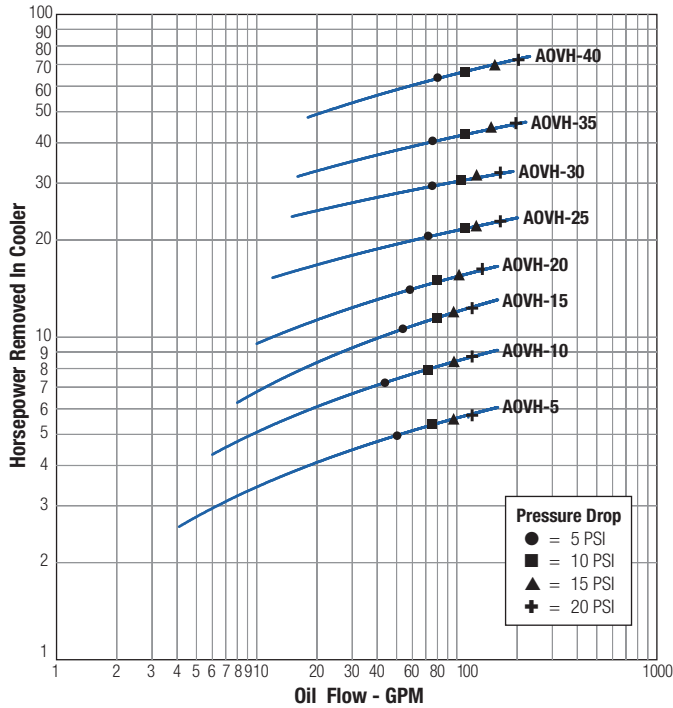

### Two Pass Oil (AOVH or AOVHR)

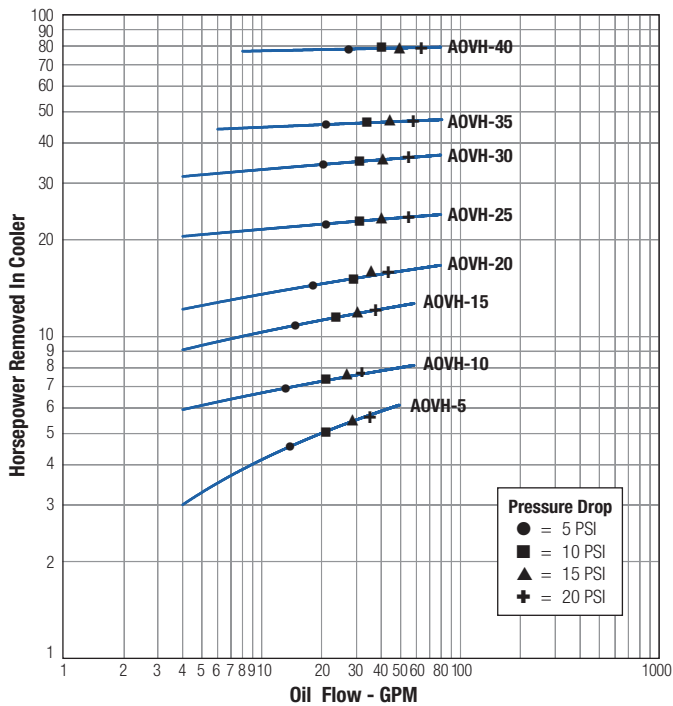

## Selection Procedure

Performance Curves are based on 50SSU oil leaving the cooler 40°F higher than the ambient air temperature used for cooling. This is also referred to as a 40°F approach temperature.

**STEP 1 Determine the Heat Load.** This will vary with different systems, but typically coolers are sized to remove 25 to 50% of the input nameplate horsepower.  
(Example: 100 HP Power Unit x .33 = 33 HP Heat load.)  
If BTU/HR is known:  $HP = \frac{BTU/HR}{2545}$

**STEP 1 Determine Approach Temperature.** Desired oil leaving cooler °F – Ambient air temp. °F = Actual Approach

**STEP 1 Determine Curve Horsepower Heat Load.** Enter the information from above:

$$\text{Horsepower heat load} \times \frac{40 \times Cv}{\text{Actual Approach}} = \text{Curve Horsepower}$$

**STEP 1 Enter curves** at oil flow through cooler and curve horsepower. Any curve above the intersecting point will work.

**STEP 1 Determine Oil Pressure Drop from Curves:**

● = 5 PSI   ■ = 10 PSI   ▲ = 15 PSI   + = 20 PSI  
Multiply pressure drop from curve by correction factor found in oil  $\Delta P$  correction curve.

### Desired Reservoir Temperature

**Return Line Cooling:** Desired temperature is the oil temperature leaving the cooler. This will be the same temperature that will be found in the reservoir.

**Off-Line Recirculation Cooling Loop:** Desired temperature is the oil temperature entering the cooler. In this case, the oil temperature change must be determined so that the actual oil leaving temperature can be found.

Calculate the oil temperature change (oil  $\Delta T$ ) with this formula:

$$\text{Oil } \Delta T = (BTU's/HR) / (GPM \text{ Oil Flow} \times 210)$$

To calculate the oil leaving temperature from the cooler, use this formula:

$$\text{Oil Leaving Temp.} = \text{Oil Entering Temp.} - \text{Oil } \Delta T$$

This formula may also be used in any application where the only temperature available is the entering oil temperature.

**Oil Pressure Drop:** Most systems can tolerate a pressure drop through the heat exchanger of 20 to 30 PSI. Excessive pressure drop should be avoided. Care should be taken to limit pressure drop to 5 PSI or less for case drain applications where high back pressure may damage the pump shaft seals.

### Oil Pressure Correction

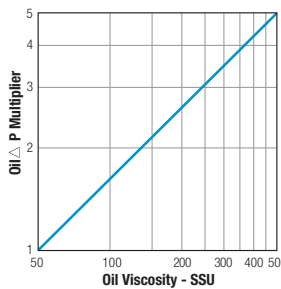

### Oil Temperature

Typical operating temperature ranges are:

Hydraulic Motor Oil	110°- 130°F
Hydrostatic Drive Oil	130°- 180°F
Bearing Lube Oil	120°- 160°F
Lube Oil Circuits	110°- 130°F

\* To register for **XSelector®** please go to [www.thermaltransfer.com/get-in-touch/](http://www.thermaltransfer.com/get-in-touch/) and complete the **XSelector®** Inquiry form and submit.

Download the **XSelector®** for both Apple and Android formats by searching for **XSelector®** in their App Stores. You must first register for **XSelector®** before using it on mobile devices.

\*\* For Salt Water applications a Zinc Anode needs to be plumbed in the water inlet of the cooler to prevent corrosion.

# Specifications

## Electric motor & Fan data\*

Model	CFM	Sound dB(A)* at 7 FT	HP	Volts	Phase	Full Load Amps	HZ	Nema Frame	RPM	Type	Circuit	Thermal Overload	Bearing B-Ball
AOVH-5	780	85	1/2	115/208-230	1	7.4/3.9-3.7	60	48	3450	TEFC	C	No	B
	780	85	1/2	208-230/460	3	2.1-2./1.	60	48	3450	TEFC	D	No	B
AOVH-10	1110	85	1/2	115/208-230	1	7.4/3.9-3.7	60	48	3450	TEFC	A	No	B
	1110	85	1/2	208-230/460	3	2.1-2./1.	60	48	3450	TEFC	D	No	B
AOVH-15	1590	91	1/2	115/208-230	1	7.4/3.9-3.7	60	48	3450	TEFC	A	No	B
	1590	91	1/2	208-230/460	3	2.1-2./1.	60	48	3450	TEFC	D	No	B
AOVH-20	2168	91	1/2	115/208-230	1	7.4/3.9-3.7	60	48	3450	TEFC	C	No	B
	2168	91	1/2	208-230/460	3	2.1-2./1.	60	48	3450	TEFC	D	No	B
AOVH-25	3000	81	1	115/208-230	1	12.4/6.5-6.2	60	56	1725	TEFC	C	No	B
	3000	81	1	208-230/460	3	3.6-3.4/1.7	60	56	1725	TEFC	D	No	B
AOVH-30	4095	84	1	115/208-230	1	12.4/6.5-6.2	60	56	1725	TEFC	C	No	B
	4095	84	1	208-230/460	3	3.6-3.4/1.7	60	56	1725	TEFC	D	No	B
AOVH-35	Not Available				1	9.-8.6/4.3	60	182T	1725	TEFC	D	No	B
	5921	89	3	208-230/460	3	9.-8.6/4.3	60	182T	1725	TEFC	D	No	B
AOVH-40	Not Available				1	9.-8.6/4.3	60	182T	1725	TEFC	D	No	B
	9609	91	3	208-230/460	3	9.-8.6/4.3	60	182T	1725	TEFC	D	No	B

\*Published electrical ratings are approximate, and may vary because of motor brand. Actual ratings are on motor nameplate.

\*\*Catalog dB(A) sound levels are at seven (7) feet. dB(A) sound levels increase by six (6) dB(A) for halving this distance and decrease by six (6) dB(A) for doubling this distance.

## Explosion Proof Motors (Class I GP.D & Class II GP.F, G)\*

Model	CFM	Sound dB(A)* at 7 FT	HP	Volts	Phase	Full Load Amps	HZ	Nema Frame	RPM	Type	Circuit	Thermal Overload	Bearing B-Ball
AOVH-5	780	85	1/2	115/230	1	7.4/3.7	60	48	3450	FC	C	Yes	B
	780	85	1/2	208-230/460	3	2.4-2.2/1.1	60	48	3450	FC	D	Yes	B
AOVH-10	1110	85	1/2	115/230	1	7.4/3.7	60	48	3450	FC	C	Yes	B
	1110	85	1/2	208-230/460	3	2.4-2.2/1.1	60	48	3450	FC	D	Yes	B
AOVH-15	1590	91	1/2	115/230	1	7.4/3.7	60	48	3450	FC	C	Yes	B
	1590	91	1/2	208-230/460	3	2.4-2.2/1.1	60	48	3450	FC	D	Yes	B
AOVH-20	2168	91	1/2	115/230	1	7.4/3.7	60	48	3450	FC	C	Yes	B
	2168	91	1/2	208-230/460	3	2.4-2.2/1.1	60	48	3450	FC	D	Yes	B
AOVH-25	3000	81	1	115/230	1 ▲	12.4/6.2	60	56	1725	FC	C	Yes	B
	3000	81	1	230/460	3	3.4/1.7	60	56	1725	FC	D	No	B
AOVH-30	4095	84	1	115/230	1 ▲	12.4/6.2	60	56	1725	FC	C	Yes	B
	4095	84	1	230/460	3	3.4/1.7	60	56	1725	FC	D	No	B
AOVH-35	Not Available				1	8.6/4.3	60	182T	1725	FC	D	No	B
	5921	89	3	230/460	3	8.6/4.3	60	182T	1725	FC	D	No	B
AOVH-40	Not Available				1	8.6/4.3	60	182T	1725	FC	D	No	B
	9609	91	3	230/460	3	8.6/4.3	60	182T	1725	FC	D	No	B

\*Published electrical ratings are approximate, and may vary because of motor brand. Actual ratings are on motor nameplate.

▲ = CL. 1, GP. D only TEFC = Totally enclosed, fan cooled FC = Fan cooled C = Capacitor start - Induction run D = Squirrel cage

## C<sub>v</sub> Viscosity Correction

Average Oil Temp °F	OIL					
	SAE 5 110 SSU at 100°F 40 SSU at 210°F	SAE 10 150 SSU at 100°F 43 SSU at 210°F	SAE 20 275 SSU at 100°F 50 SSU at 210°F	SAE 30 500 SSU at 100°F 65 SSU at 210°F	SAE 40 750 SSU at 100°F 75 SSU at 210°F	50-50 Ethylene Glycol & Water
100	1.14	1.22	1.35	1.58	1.77	1.11
150	1.01	1.05	1.11	1.21	1.31	1.02
200	.99	1.00	1.01	1.08	1.10	.96
250	.95	.98	.99	1.00	1.00	.95

# Dimensions

For 3D models and spec sheets visit the AOVH product page on our website. <https://www.thermaltransfer.com/product/aovh-series>

Model	A	B	C	D	E	F	G	K	L	M		N	P	Q	Net Weight (LBS)
										NPT Male	SAE Female				
AOVH-5	7.40	14.81	5.90	11.81	19.93	9.19	8.31	3.84	7.69	1½"	#24 SAE 1½-12UN Thread	5.84	11.69	16.81	67
AOVH-10	9.50	19.00	6.56	13.12	19.49	10.50	12.50	4.44	8.88	1½"		7.94	15.88	21.00	78
AOVH-15	10.19	20.38	7.87	15.75	19.49	13.12	13.88	5.75	11.50	1½"		8.62	17.25	22.38	90
AOVH-20	11.91	23.81	9.19	18.38	19.49	15.75	17.19	7.00	14.00	2"	#32 SAE 2½-12UN Thread	10.28	20.56	25.81	110
AOVH-25	13.34	26.68	11.81	23.62	23.58	21.00	20.19	9.62	19.25	2"		11.78	23.56	28.68	157
AOVH-30	15.81	31.62	13.78	27.56	23.33	24.94	25.12	11.59	23.19	2"		14.25	28.50	33.62	190
AOVH-35	16.90	33.81	15.09	30.19	23.06	27.56	27.31	12.90	25.81	2"		15.34	30.69	35.81	315
AOVH-40	20.18	41.62	18.37	36.75	23.06	34.12	35.12	16.19	32.38	2"	19.25	38.50	43.62	350	

NOTE: All dimensions in inches.

## Fan Rotation Clockwise/Facing Motor Shaft

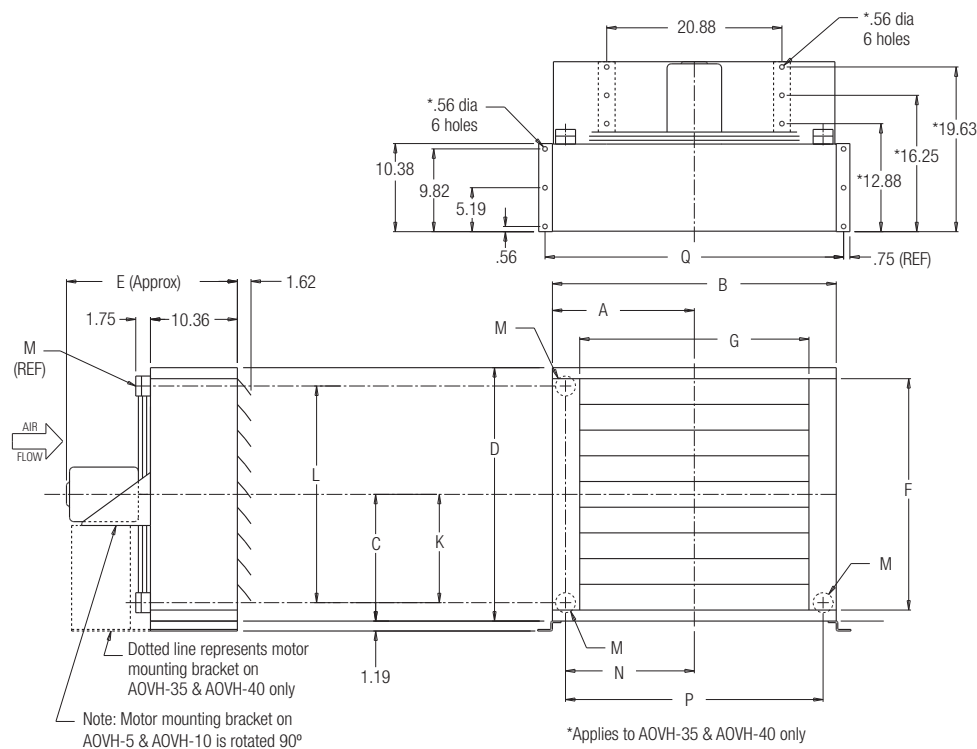

## Lubrication Notes

**Caution:** Do not over oil or over grease. **Ball bearings** – No grease needed at start up. Grease as follows:

5,000 Hours/Year	5 Year Grease Interval
Continuous — Normal Applications	2 Years
Seasonal Service — Motor is idle for 6 months or more	1 Year
Continuous — High ambients, dirty or moist locations, high vibration	6 Months



HydroThrift Corporation

1301 Sanders Ave SW

Massillon, OH 44647 USA

[sales@hydrothrift.com](mailto:sales@hydrothrift.com) 330-837-5141