

# TYPE 9 IMMERSION PLATE

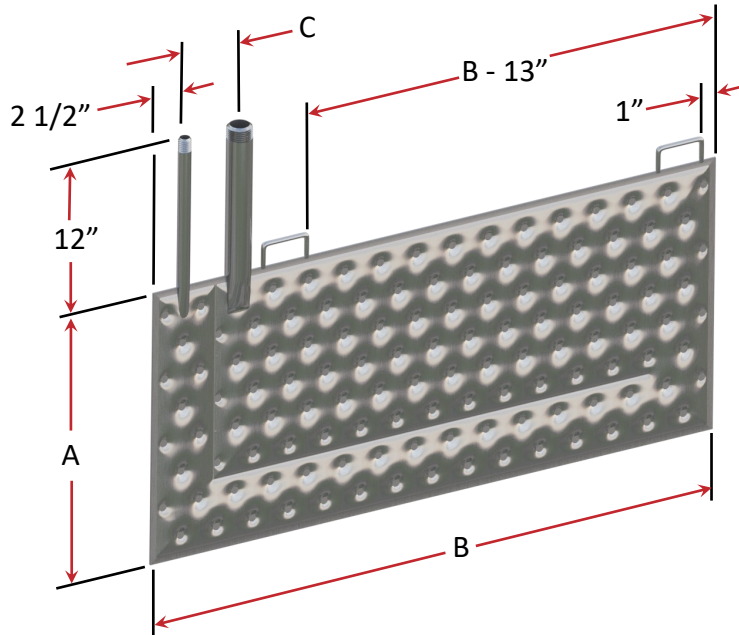

The **TYPE 9** immersion plate is designed for steam service. The plate is equipped with a larger steam inlet nozzle feeding the open portion of the plate where the steam or vapor is condensed, while the bottom portion of the plate is configured with a condensate discharge baffle providing a control path for driving out the condensate.

Optional plate hangers are available for easy installation.

**Standard Specifications:**

Surface Type: Double Embossed  
 Sheet Thickness: 14ga. (0.075")  
 MOC: 304 Stainless Steel  
 Pressure Rating: 150 PSIG / 400°F

NOZZLE SCHEDULE		
INLET	OUTLET	(C)
1" NPT	3/4" NPT	4"
1 1/2" NPT	3/4" NPT	4"
2" NPT	1" NPT	6"

Standard nozzles are Male NPT

**PLATE SURFACE AREA CHART**

(A) - PLATE HEIGHT, Inches	(B) - PLATE LENGTH, Inches											AREA = ft <sup>2</sup>
	23	29	35	47	59	71	83	95	107	119	131	
12	3.8	4.8	5.8	7.8	9.8	11.8	13.8	15.8	17.8	19.8	21.8	23.8
18	5.8	7.3	8.8	11.8	14.8	17.8	20.8	23.8	26.8	29.8	32.8	35.8
22	7.0	8.9	10.7	14.4	18.0	21.7	25.4	29.0	32.7	36.4	40.0	43.7
26	8.3	10.5	12.6	17.0	21.3	25.6	30.0	34.3	38.6	43.0	47.3	51.6
29	9.3	11.7	14.1	18.9	23.8	28.6	33.4	38.3	43.1	47.9	52.8	57.6
36	11.5	14.5	17.5	23.5	29.5	35.5	41.5	47.5	53.5	59.5	65.5	71.5
43	13.7	17.3	20.9	28.1	35.2	42.4	49.6	56.7	63.9	71.1	78.2	85.4
48	15.3	19.3	23.3	31.3	39.3	47.3	55.3	63.3	71.3	79.3	87.3	95.3

Contact our office for available stock sizes and additional arrangements.  
 Designs also available with an ASME U Stamp, bang pads, riser sleeves, and special finishes.

