

# TYPE 8 IMMERSION PLATE

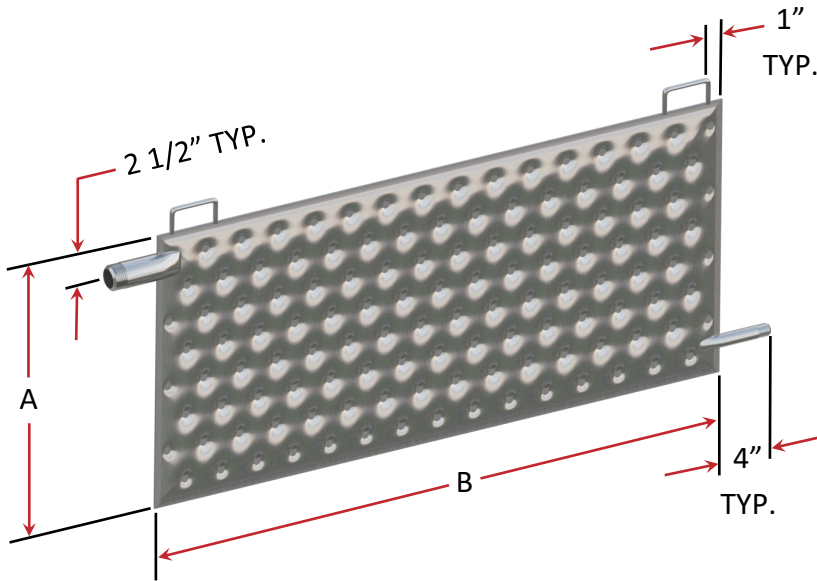

The **TYPE 8** immersion plate is a very versatile plate design that is suitable for most service medias, including steam, liquids, and refrigerants. The open (non-baffled) plate design along with the staggered nozzle arrangement on the ends of the plates works for condensing and evaporating 2-phase medias, as well as high volume liquid flow rates.

Optional handles and plate hangers can be added for easy installation.

### Standard Specifications:

Surface Type: Double Embossed  
 Sheet Thickness: 14ga. (0.075")  
 MOC: 304 Stainless Steel  
 Pressure Rating: 150 PSIG / 400°F

### NOZZLE SCHEDULE

INLET (UPPER)	OUTLET (LOWER)
1" NPT	3/4" NPT
1 1/2" NPT	3/4" NPT
2" NPT	1" NPT

Standard nozzles are Male NPT

### PLATE SURFACE AREA CHART

(A) - PLATE HEIGHT, Inches	(B) - PLATE LENGTH, Inches											AREA = ft <sup>2</sup>
	23	29	35	47	59	71	83	95	107	119	131	
12	3.8	4.8	5.8	7.8	9.8	11.8	13.8	15.8	17.8	19.8	21.8	23.8
18	5.8	7.3	8.8	11.8	14.8	17.8	20.8	23.8	26.8	29.8	32.8	35.8
22	7.0	8.9	10.7	14.4	18.0	21.7	25.4	29.0	32.7	36.4	40.0	43.7
26	8.3	10.5	12.6	17.0	21.3	25.6	30.0	34.3	38.6	43.0	47.3	51.6
29	9.3	11.7	14.1	18.9	23.8	28.6	33.4	38.3	43.1	47.9	52.8	57.6
36	11.5	14.5	17.5	23.5	29.5	35.5	41.5	47.5	53.5	59.5	65.5	71.5
43	13.7	17.3	20.9	28.1	35.2	42.4	49.6	56.7	63.9	71.1	78.2	85.4
48	15.3	19.3	23.3	31.3	39.3	47.3	55.3	63.3	71.3	79.3	87.3	95.3

Contact our office for available stock sizes and additional arrangements.  
 Designs also available with an ASME U Stamp, bang pads, riser sleeves, and special finishes.

