

REAR MOUNT COOLERS

Air Cooled—INDUSTRIAL/RM Series

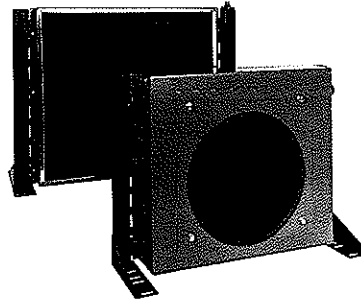

COMPACT, EFFICIENT DESIGN

**LOW COST CASE
DRAIN COOLING**

**WIDE SELECTION TO FIT
MOST TEFC MOTORS**

- Mounts Behind Existing TEFC Motor for Compact, Low Cost Application
- For 1 to 100 HP TEFC Electric Motors
- SAE, NPT or Metric Connections
- Mounting Brackets Included

REAR MOUNT

air cooled

MATERIALS

Tubes - Copper

Fins - Aluminum

Turbulator - Aluminum

Cabinet - Steel with baked enamel finish

Filter - Stainless frame with washable media

Manifolds - Copper; RM-08

Steel; RM-19 & RM-24

Connections - Brass; RM-08

Steel; RM-19 & RM-24

Nameplate - Aluminum

RATINGS

Operating pressure - 300 psi

Test pressure - 300 psi

Operating temperature - 350°F

HOW TO ORDER - RM-08 MODELS ONLY

RM	—	0	8	—		
MODEL SERIES		MODEL SIZE SELECTED			FLUID PASSES	*CONNECTION TYPE
					1 = 1 PASS	1 = NPT
					2 = 2 PASS	2 = SAE
					4 = 4 PASS	3 = BSPP

HOW TO ORDER - ALL MODELS EXCEPT RM-08 SIZE

RM	—			—		
MODEL SERIES		MODEL SIZE SELECTED			FLUID PASSES	*CONNECTION TYPE
					1 = 1 PASS	1 = NPT
					2 = 2 PASS	2 = SAE
						3 = BSPP

SPECIFICATIONS

Model	A	B	C	D	E	F		G		H	J	K	L	M	N	NET WTS.				
						SAE	NPT/BSPP	SAE	NPT/BSPP											
RM-19-1*	13.62	16.50	5.11	10.31	15.00	#12	.75	3.05	4.12	14.75	7.38	6.81	10.38	5.81	7.50	16				
RM-19-2*				4.31	6.00											16				
RM-24-1*	19.62	24.75	5.85	16.31	23.25					#12	.75	3.05	4.12	21.44	10.72	9.81	14.62	8.56	12.00	31
RM-24-2*				4.31	12.00															31

Note: We reserve the right to make reasonable design changes without notice. All dimensions are in inches.

DIMENSIONS—RM-19, RM-24 MODELS

RM-19-1*, RM-24-1*

ONE PASS

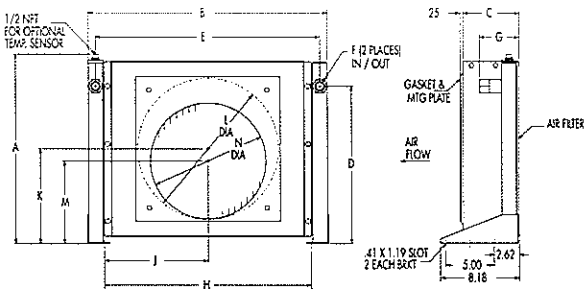

RM-19-2*, RM-24-2*

TWO PASS

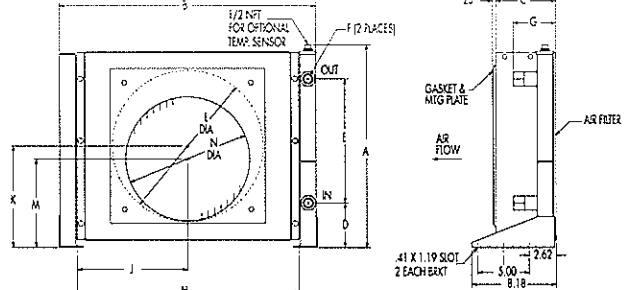

DIMENSIONS—RM-08 MODELS ONLY

RM-08-1*, ONE PASS

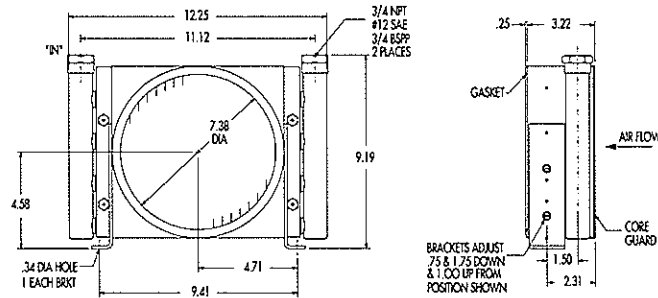

RM-08-2*, TWO PASS

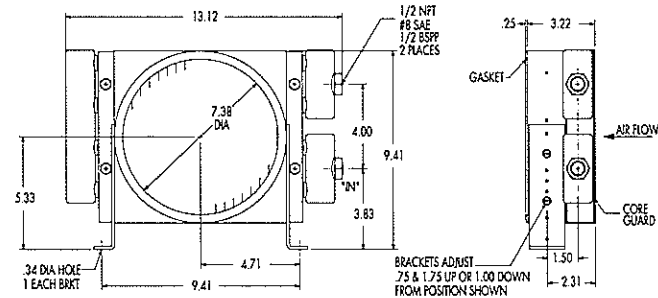

RM-08-4*, FOUR PASS

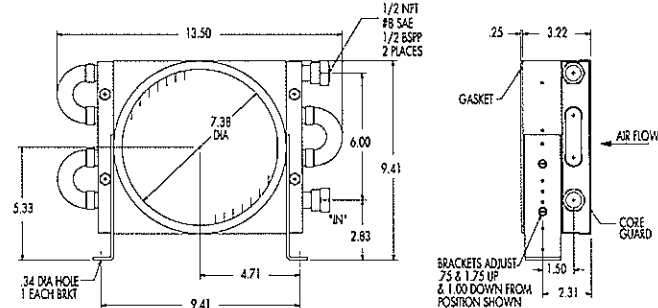

Note: We reserve the right to make reasonable design changes without notice. All dimensions are in inches.

air cooled
REAR MOUNT

PERFORMANCE CURVES

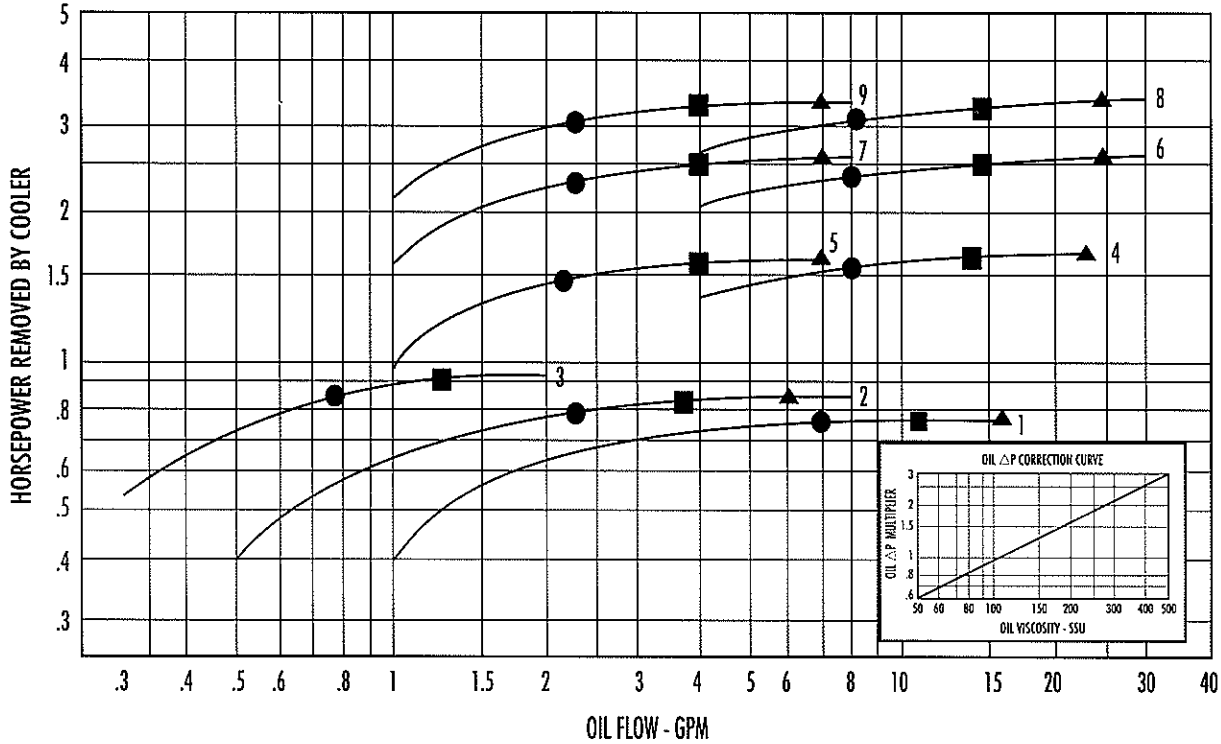

SELECTION PROCEDURE

Performance Curves are based on 100SSU oil leaving the cooler 40°F higher than the ambient air temperature used for cooling and 1800 RPM motor speed. This is also referred to as a 40° approach temperature.

Step 1. Determine the Heat Load.

This will vary with different systems, but typically coolers are sized to remove 25 to 50% of the input nameplate horsepower. (Example: 100 HP Power Unit x .33 = 33 HP Heat load.) (for 1200 RPM motors, multiply Heat Load by 1.5). If BTU/Hr. is known: $HP = \frac{BTU/Hr}{2545}$

Step 2. Determine Approach Temperature.

Desired oil leaving cooler °F - Ambient air temp. °F = Actual Approach.

Step 3. Determine Curve Horsepower Heat Load.

Enter the information from above:
 $\text{Horsepower heat load} \times \frac{40}{\text{Actual Approach}} = \text{Curve Horsepower}$

Step 4. Enter curves at oil flow through cooler and curve horsepower. Any curve above the intersecting point will work.

Step 5. Determine Oil Pressure Drop from Curves:

● = 5 PSI; ■ = 10 PSI; ▲ = 20 PSI. Multiply pressure drop from curve by correction factor found in oil ΔP correction curve.

Oil Temperature: Typical operating temperature ranges are:
 Hydraulic Oil: 110°F - 130°F, Hydrostatic Drive Oil: 130°F - 180°F,
 Bearing Lube Oil: 120°F - 160°F, Lube Oil Circuits: 110°F - 130°F.

Oil Pressure Drop: Most systems can tolerate a pressure drop through the heat exchanger of 20 to 30 PSI. Excessive pressure drop should be avoided. Care should be taken to limit pressure drop to 5 PSI or less for case drain applications where high back pressure may damage the pump shaft seals.

Curve	Model	TEFC Motor Frame Sizes
1	RM-08-1*	48-184
2	RM-08-2*	
3	RM-08-4*	
4	RM-19-1*	213-256
5	RM-19-2*	
6	RM-24-1*	254-286
7	RM-24-2*	
8	RM-24-1*	324-365
9	RM-24-2*	

For more information or to purchase these products, please contact:
HYDROTHRIFT CORPORATION
 1-800-773-0493
www.hydrothrift.com
sales@hydrothrift.com

REAR MOUNT
air cooled