

# AIR COOLED MOBILE/DH SERIES

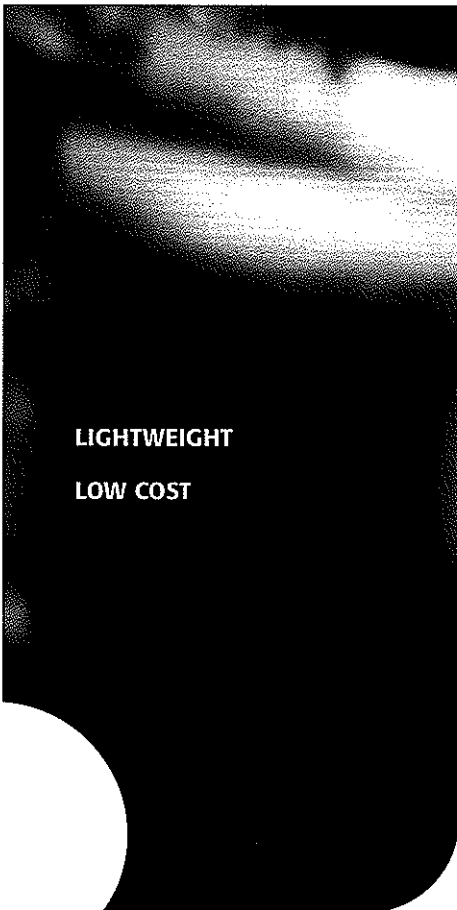

**LIGHTWEIGHT**  
**LOW COST**

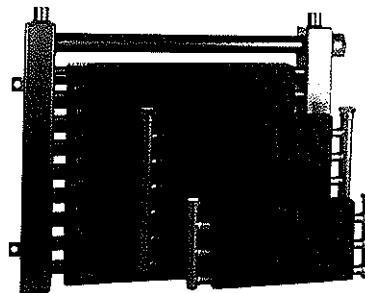

- High Performance Oil Turbulators
- Rugged Off-Highway Steel Designs Available
- Oil Flows to 150 GPM, Heat Removal to 175,000 BTU/HR

### OPTIONS:

- Built-in Relief Bypass
- Steel Components
- Custom Sizes/Mounting Brackets
- Connection Sizes/Locations
- Marine Coating

## MATERIALS

**Tubes** - Copper  
**Fins** - Aluminum or Steel  
**Turbulator** - Aluminum

**Manifolds** - Copper; Models DH-051–DH-447  
Steel; Models DH-513–DH-670  
**Connections** - Brass; Models DH-051–DH-447  
Steel; Models DH-513–DH-670

## RATINGS

**Operating pressure** - 300 psi  
**Test pressure** - 300 psi  
**Operating temperature** - 350°F

air cooled  
DH/DF

## HOW TO ORDER

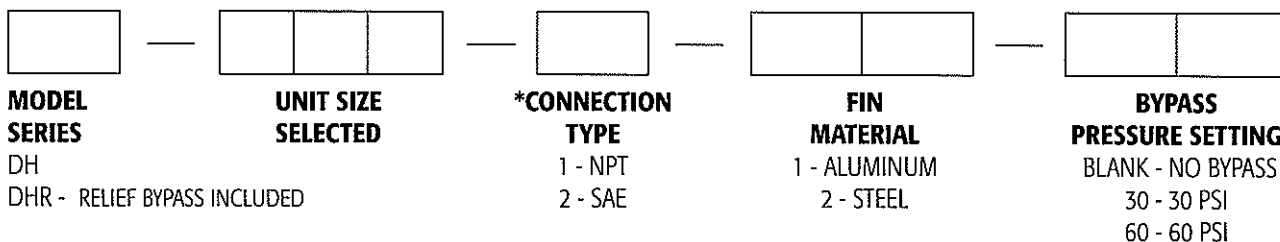

Examples: DH-051-1-1 or DHR-062-2-2-30

**Note: All positions must be filled. Mounting Kits (where needed) must be ordered separately, by part number.**

\*Other connection types available. Please consult factory for assistance.

# DIMENSIONS & WEIGHTS FOR DH-051 THROUGH DH-447 (COPPER MANIFOLD, 1 ROW)

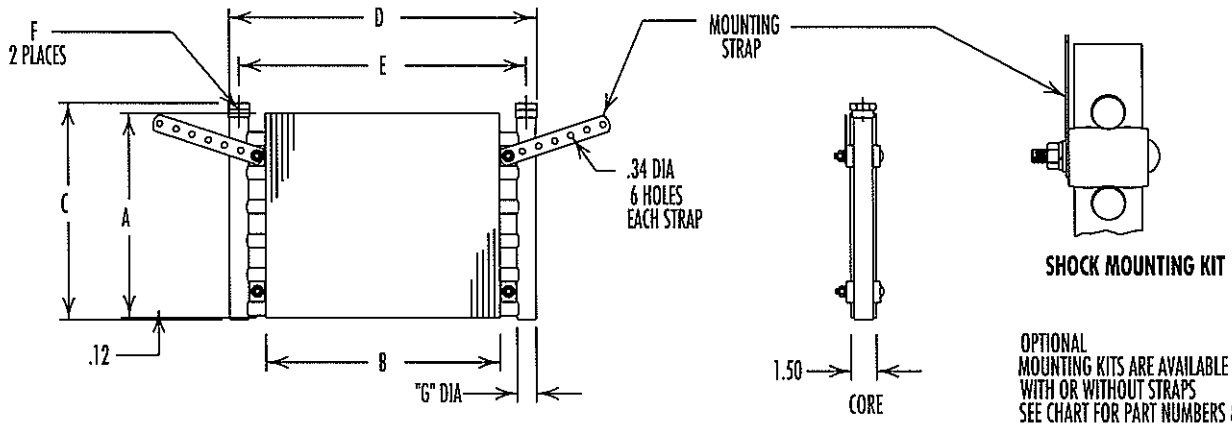

OPTIONAL MOUNTING KITS ARE AVAILABLE WITH OR WITHOUT STRAPS SEE CHART FOR PART NUMBERS & QUANTITIES

MODEL	A	B	C	D	E	F		G DIA	QTY MTG KITS	FACE AREA FT <sup>2</sup>	WEIGHT LBS.										
						NPT	SAE														
DH-051	4.00	11.25	4.50	15.00	14.12	.50	#10	.88	2	.31	2										
DH-062	6.00			6.50	15.00					14.12	.47	3									
DH-073		14.25	18.00		17.12					.60	3										
DH-084		20.25	24.00		23.12					.84	4										
DH-095	8.00	8.50	18.00	17.12	.75					#12	1.12	4	.79	4							
DH-106													14.25	21.00	20.12	.96	5				
DH-117													17.25	24.00	23.12	1.12	5				
DH-194	12.00	12.73	18.00	16.88									1.00	#16	1.38	6	1.15	6			
DH-205																	13.75	21.00	19.88	1.40	7
DH-216																	16.75	24.00	22.88	1.64	8
DH-227	14.00	19.75	14.73	24.00		22.88	1.25	#20	1.62				8	1.92	9						
DH-249	18.00													18.73	24.00	22.88	2.47	12			
DH-326	24.00	19.25	25.00	24.00		22.62	1.00	#16	1.38				8	3.21	16						
DH-337				25.25		30.00								28.62	4.21	20					
DH-348	30.00	19.25	31.00	24.00	22.62	4.00				19											
DH-359				25.25	30.00	28.62				5.26	24										
DH-370				31.25	36.00	34.62				6.51	28										
DH-425	36.00	24.75	37.41	30.00	28.38	1.25				#20	1.62	8		6.19	32						
DH-447	40.00	36.75	41.41	42.00	40.38									10.21	43						

All dimensions in inches.

After making your base model selection with the connection of your choice, please refer to the How To Order section.

Note: We reserve the right to make reasonable design changes without notice. Weights are for Aluminum fins.

## MOUNTING KITS

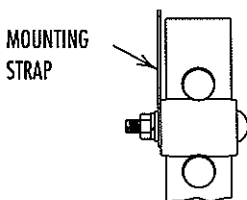

SHOCK MOUNTING KIT PART NUMBERS	
With Strap	L-84741
Without Strap	L-84740

# DIMENSIONS & WEIGHTS FOR DH-513 THROUGH DH-670 (STEEL MANIFOLD, 12 ROW)

## DH Series

## DHR Series

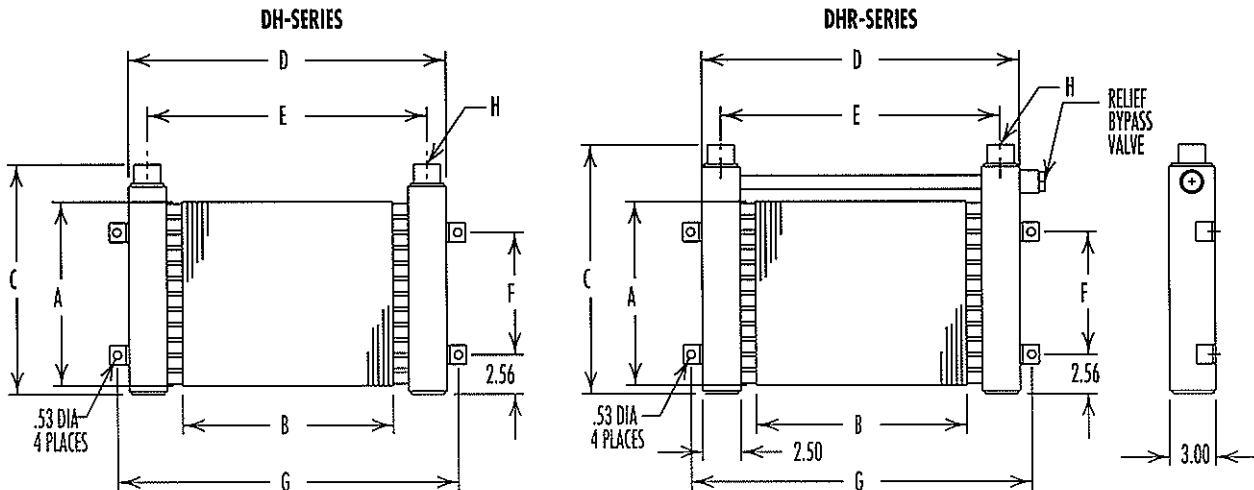

MODEL	A	B	C		D		E	F	G	H		FACE AREA FT <sup>2</sup>	WEIGHT LBS.
			DH	DHR	DH	DHR				NPT	SAE		
DH-513	12.00	13.75	15.00	16.25	20.75	22.41	18.25	8.00	22.25	.75	#12	1.15	16
DH-524	18.00	19.75	21.00	23.25	26.75	28.13	24.25	14.00	28.25			3.21	53
DH-535	24.00	19.25	27.00	29.25	26.25	27.63	23.75	20.00	27.75	2.00	#32	5.69	60
DH-626	36.00	22.75	39.03	41.28	29.75	31.13	27.25	32.00	31.25			9.65	115
DH-670	40.00	34.75	43.03	45.28	41.75	43.13	39.25	36.00	43.25				

All dimensions in inches. After making your base model selection with the connection of your choice, please refer to the How To Order section. Weights are for aluminum fins.

**Oil Temperature:** Oil coolers can be selected using *entering* or *leaving* oil temperatures.

Typical operating temperature ranges are:

Hydraulic Oil: 110°F - 130°F, Hydrostatic Drive Oil: 130°F - 180°F,

Bearing Lube Oil: 120°F - 160°F, Lube Oil Circuits: 110°F - 130°F.

### Desired Reservoir Temperature

**Return Line Cooling:** Desired temperature is the oil temperature leaving the cooler. This will be the same temperature that will be found in the reservoir.

**Off-Line Recirculation Cooling Loop:** Desired temperature is the oil temperature *entering* the cooler. In this case, the oil temperature change must be determined so that the actual oil leaving temperature can be found.

Calculate the oil temperature change (oil  $\Delta T$ ) with this formula:

$$\text{Oil } \Delta T = (\text{BTU's/Hr.}) / (\text{GPM Oil Flow} \times 210).$$

To calculate the oil leaving temperature from the cooler, use this formula:

$$\text{Oil Leaving Temp.} = \text{Oil Entering Temp.} - \text{Oil } \Delta T.$$

This formula may also be used in any application where the only temperature available is the entering oil temperature.

**Oil Pressure Drop:** Most systems can tolerate a pressure drop through the heat exchanger of 20 to 30 PSI. Excessive pressure drop should be avoided. Care should be taken to limit pressure drop to 5 PSI or less for case drain applications where high back pressure may damage the pump shaft seals.

## METHODS TO DETERMINE HEAT LOADS

The heat load may be determined by:

- Hydraulic oil cooling: Assume 30% of the input horsepower will be rejected to heat. If the input horsepower is unknown, this formula may be used:  

$$\text{BTU/HR} = (\text{System PSI}) \times (\text{GPM Flow}) \times 1.8 \times .3$$
- Hydrostatic oil cooling: Assume 25% of the input horsepower will be rejected to heat.
- Automatic transmission: Assume 30% of the engine horsepower will be rejected to heat.
- Engine oil cooling: Assume 10% of the engine horsepower will be rejected to heat.

Oil Temp °F	TYPICAL OIL VISCOSITY, SSV				
	SAE 5	SAE 10	SAE 20	SAE 30	SAE 40
100	110	150	275	500	750
150	60	70	100	135	190
210	40	43	50	65	75

# PERFORMANCE CURVES

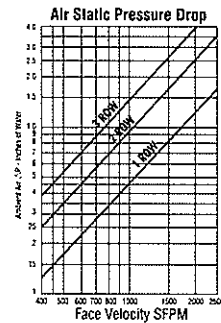
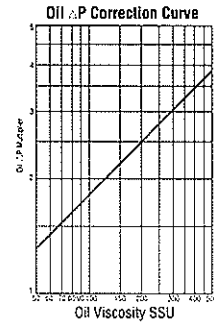
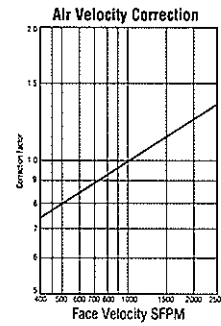
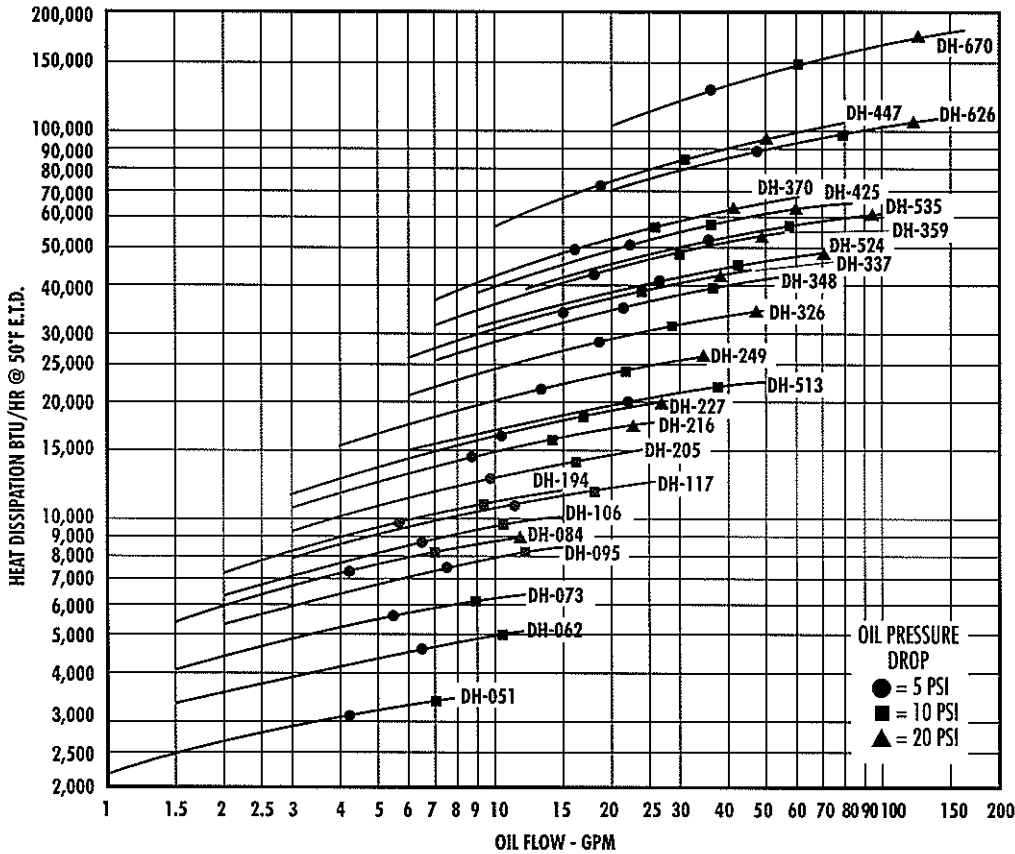

## RELIEF BYPASS OPTION

MODEL	DESCRIPTION
DH-051 thru DH-447	Available in 30psi or 60psi settings. Bypass valve is built into tubes and does not affect external dimensions. All steel valves. Not serviceable.
DH-513	Available in either 30 psi or 60 psi settings. 3/4", external all steel valve. May be removed for servicing.
DH-524 thru DH-670	Available in either 30 psi or 60 psi settings. 1-1/2", external all steel valve. May be removed for servicing.

## SELECTION PROCEDURE

Performance Curves are based on 50 SSU oil, 1000 Standard Feet per Minute (SFPM) Air Velocity, and a 50°F Entering Temperature Difference (E.T.D.)

E.T.D. = Entering oil temperature - Ambient air temperature

### Step 1: Determine Heat Load:

Heat load may be expressed as either Horsepower or BTU/Hr.

$$\text{BTU/Hr.} = \text{Horsepower} \times 2545$$

### Step 2: Determine entering temperature difference:

The entering oil temperature is generally the maximum desired system temperature.

$$\text{ETD} = \text{Entering oil temperature} - \text{Ambient air temperature}$$

### Step 3: Determine the corrected heat dissipation to use the curves:

$$\text{Corrected Heat Dissipation} = \frac{\text{BTU/Hr. (Heat Load)} \times \left( \frac{50^\circ\text{F}}{\text{Desired E.T.D.}} \right) \times \left( \frac{\text{Air Velocity}}{\text{Correction Factor}} \right)}{1}$$

Note: If air velocity is unknown assume 750 SFPM.

**Step 4:** Enter the Performance Curves at the bottom with the GPM oil flow and proceed upward to the adjusted heat load from step 3. Any curve on or above this point will meet these conditions.

**Step 5:** Calculate actual SFPM Air Velocity or SCFM (Standard Cubic Feet Per Minute) using the Face Area from the table.

$$\text{A.) } * \text{SFPM Air Velocity} = \frac{\text{SCFM Air Flow}}{\text{Square Feet Face Area}}$$

$$\text{B.) } \text{SCFM Air Flow} = \text{SFPM Air Velocity} \times \text{Square Feet Face Area}$$

\*If the Air Velocity calculated is different than the value in Step 3, recheck Corrected oil Pressure Drop.

**Step 6:** Multiply Oil Pressure Drop from curve by correction factor found in Oil ΔP Correction Curve.

DH/DF  
air cooled

# AIR COOLED MOBILE/DF SERIES

**LOW AMP DRAW  
12 OR 24 VOLT DC MOTORS**

**HEAVY DUTY CONSTRUCTION**

**OPTIONAL SERVICEABLE  
RELIEF BYPASS VALVE**

**OPTIONAL FAN  
CONTROL SWITCH**

**LONG LIFE HYDRAULIC  
MOTORS**

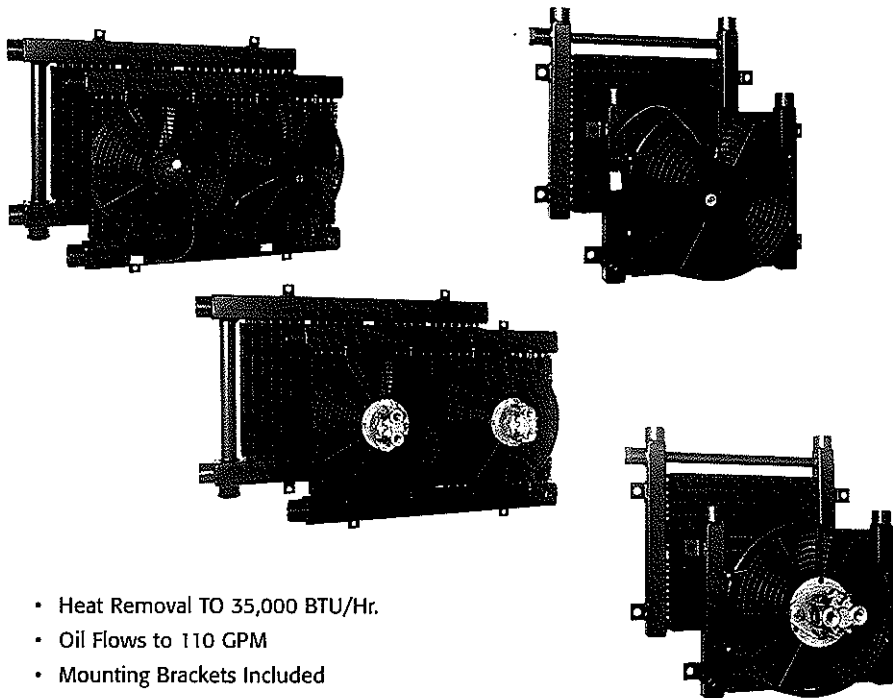

- Heat Removal TO 35,000 BTU/Hr.
- Oil Flows to 110 GPM
- Mounting Brackets Included
- SAE, NPT or 37° Flare Oil Connections
- Damage Resistant Steel Fins
- Rugged Steel Manifolds

## MATERIALS

**Fins** - Steel  
**Tubes** - Copper  
**Manifolds** - Steel  
**Turbulators** - Aluminum

**Fan Assembly** - High Impact Plastic  
**Motor Displacement** - .22in<sup>3</sup>/Rev. (Hydraulic)  
**Maximum Pressure** - 2000 PSI (Hydraulic)  
**Allowable Backpressure** - 1000 PSI (Hydraulic)

## RATINGS

**Operating pressure** - 300 psi  
**Test pressure** - 300 psi  
**Operating temperature** - 350°F

air cooled  
DH/DF

NUMBER OF FANS	DC CURRENT REQUIRED	
	12 VOLT	24 VOLT
1	12.5 AMPS	6.3 AMPS
2	25 AMPS	12.6 AMPS

HYDRAULIC MOTOR DATA			
NUMBER OF FANS	OIL FLOW REQUIRED (GPM)	MIN. OPERATING PRESS. (PSI)	MAX. FAN SPEED (RPM)
1	2.1	300	2200
2	4.2	300	2200

## RELIEF BYPASS OPTION

MODEL	DESCRIPTION
DFR-11	3/4", external, all steel valve. Available in either 30 PSI or 60 PSI settings. May be removed for servicing.
DFR-12, 22	1-1/2", external, all steel valve. Available in either 30 PSI or 60 PSI settings. May be removed for servicing.

## HOW TO ORDER

<b>MODEL SERIES</b>	<b>MODEL SIZE SELECTED</b>	<b>*CONNECTION TYPE</b>	<b>MOTOR SPECIFICATION</b>	<b>RELIEF BYPASS</b>	
DF DFR - RELIEF BYPASS INCLUDED		1 - NPT 2 - SAE 7 - 37° MALE FLARE	NM - NO MOTOR 4A - 12 VOLT DC 4B - 24 VOLT DC 9 - HYDRAULIC MOTOR	BLANK - NO BYPASS 30 - 30 PSI 60 - 60 PSI	

\*Other connection types available. Please consult factory for assistance.

# PERFORMANCE CURVES

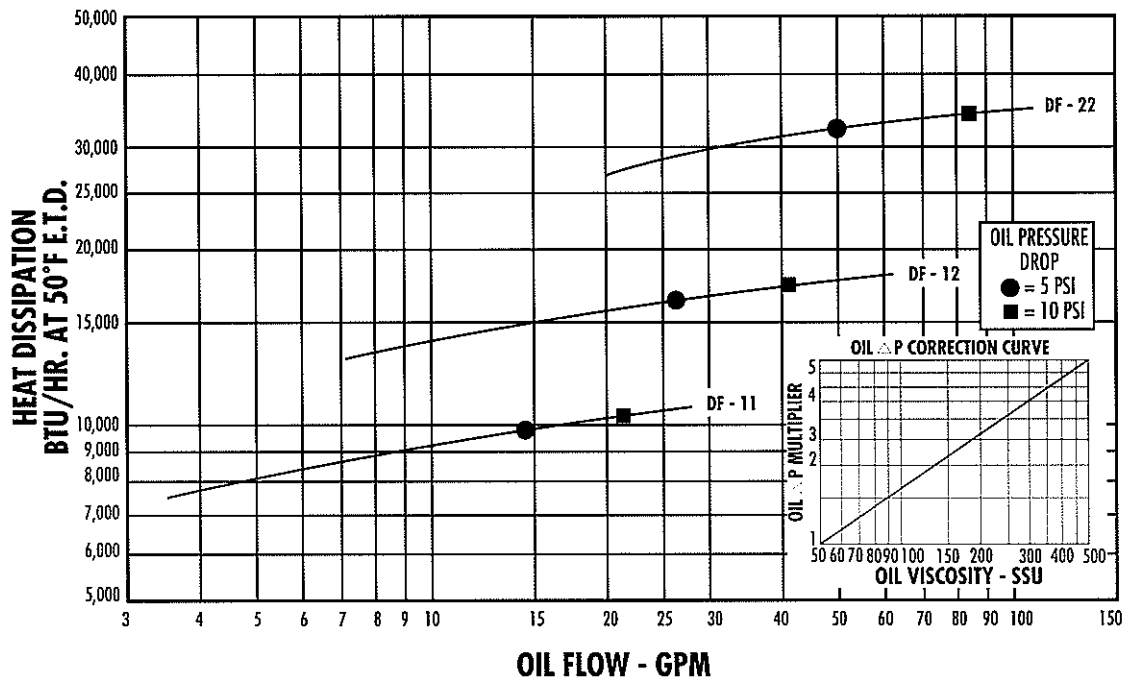

## SELECTION PROCEDURE

Performance Curves are based on 50 SSU oil entering the cooler 50°F higher than the ambient air temperature used for cooling. This is referred to as a 50°F E.T.D.

### Step 1. Determine the Heat Load.

Heat load may be expressed as either horsepower or BTU/Hr. To convert horsepower to BTU/Hr.:  
 $BTU/HR = \text{Horsepower} \times 2545$

### Step 2. Determine Entering Temperature Difference.

The entering oil temperature is generally the maximum desired oil temperature.

Entering oil temperature - Ambient air temperature = E.T.D.

### Step 3. Determine the Corrected Heat Dissipation to use the curves.

$$\text{Corrected Heat Dissipation} = \text{BTU/HR heat load} \times \frac{50^\circ\text{F}}{\text{E.T.D.}}$$

**Step 4. Enter curves** at oil flow through cooler and curve heat dissipation. Any curve above the intersecting point will work.

### Step 5. Determine Oil Pressure Drop from Curves:

● = 5 PSI; ■ = 10 PSI; Multiply pressure drop from curve by correction factor found in oil ΔP correction curve.

## METHODS TO DETERMINE HEAT LOADS

The heat load may be determined by:

- Hydraulic oil cooling: Assume 30% of the input horsepower will be rejected to heat. If the input horsepower is unknown, this formula may be used:  
 $BTU/HR = (\text{System PSI}) \times (\text{GPM Flow}) \times 1.8 \times .3$
- Hydrostatic oil cooling: Assume 25% of the input horsepower will be rejected to heat.
- Automatic transmission: Assume 30% of the engine horsepower will be rejected to heat.
- Engine oil cooling: Assume 10% of the engine horsepower will be rejected to heat.

## OIL TEMPERATURE

Typical operating temperature ranges are:

Hydraulic Motor Oil	120° - 180°F
Hydrostatic Drive Oil	160° - 180°F
Engine Lube Oil	180° - 200°F
Automatic Transmission Fluid	200° - 300°F

DH/DF  
air cooled



K

# DIMENSIONS—12 & 24 VOLT DC MOTORS

## MODELS DF-11 AND DF-12

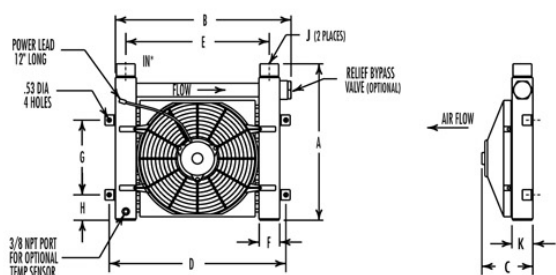

## MODEL DF-22

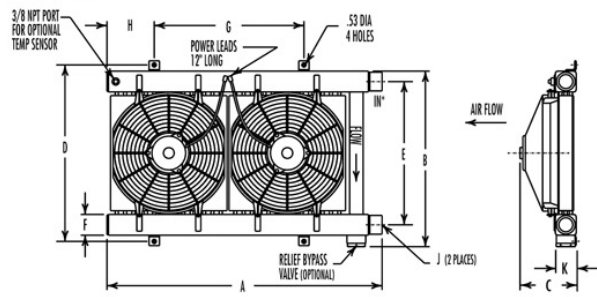

UNITS SHOWN WITH OPTIONAL BYPASS VALVE

MODEL	A		B		C	D	E	F	G	H	J		K	LBS
	DF	DFR	DF	DFR							NPT	SAE		
DF-11	16.12	18.00	19.25	20.91	5.51	20.75	17.75	1.50	7.50	3.69	1.00	#16	1.50	38
DF-12	17.00	18.25	21.25	22.91	7.01	22.75	18.75	2.50			1.50	#24	3.00	57
DF-22	31.47	33.73		22.62					22.62	14.25	7.69	1.50	110	

Note: All dimensions are in inches. We reserve the right to make reasonable design changes without notice. \*Inlet and outlet oil connections can be reversed when the bypass valve is not used.

# DIMENSIONS—HYDRAULIC MOTORS

## MODELS DF-11 AND DF-12

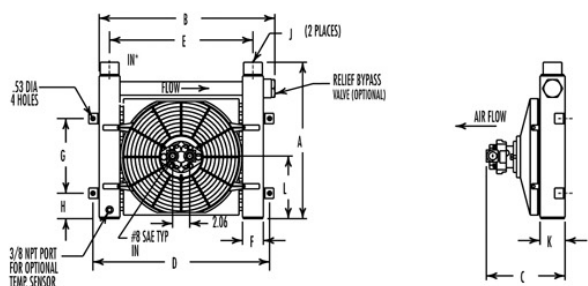

## MODEL DF-22

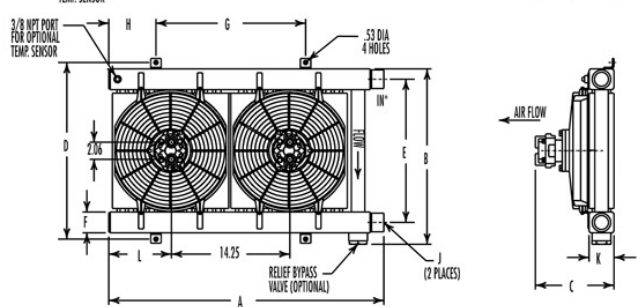

UNITS SHOWN WITH OPTIONAL BYPASS VALVE

MODEL	A		B		C	D	E	F	G	H	J		K	L	LBS
	DF	DFR	DF	DFR							NPT	SAE			
DF-11	16.12	18.00	19.25	20.91	7.47	20.75	17.75	1.50	7.50	3.69	1.00	#16	1.50	7.56	38
DF-12	17.00	18.25	21.25	22.91	9.46	22.75	18.75	2.50			1.50	#24	3.00	7.60	57
DF-22	31.47	33.73		22.62					22.62	14.25	7.69	1.50	110		

Note: All dimensions are in inches. We reserve the right to make reasonable design changes without notice. \*Inlet and outlet oil connections can be reversed when the bypass valve is not used.

air cooled  
DH/DF

12/14 / Internal, Transducer (Range 50) (Created: 5/24/04 10:49 AM by: User:KCR/Res:cm) 6.1  
Blas...  
PS Version: 2015.102 HON Version 6.2 Revision 0 NSI System 9.3 Build: #68 Ripped on Thursday, May 20, 2004 10:51:27 AM  
ID: Irock

# ELECTRICAL SCHEMATIC

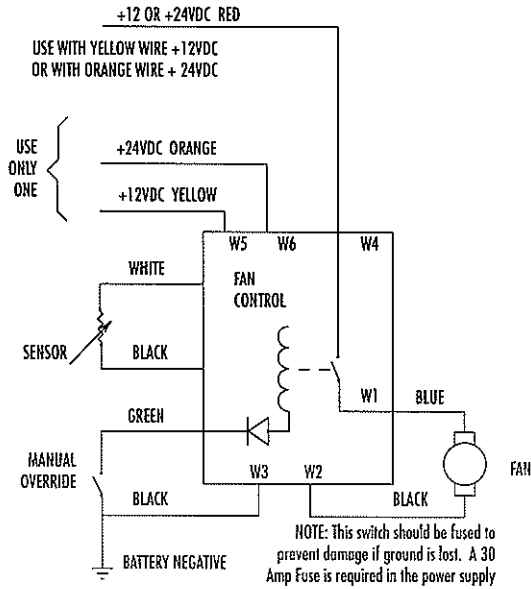

# THERMOSTATIC TEMPERATURE CONTROLLER OPTION

This controller was designed to mount on the cooler without requiring extensive wiring or plumbing. It provides accurate temperature control by cycling the cooling fan(s) to maintain desired oil temperature.

- 12 or 24 volt operation
- Adjustable temperature settings range from 100°F thru 210°F in 20°F increments
- For use with one or two fan models
- Temperature sensor provided
- Wiring provided for remote manual override
- Mounting hardware included

PART NUMBER	DESCRIPTION
96171	ELECTRONIC FAN CONTROL KIT

# DIMENSIONS

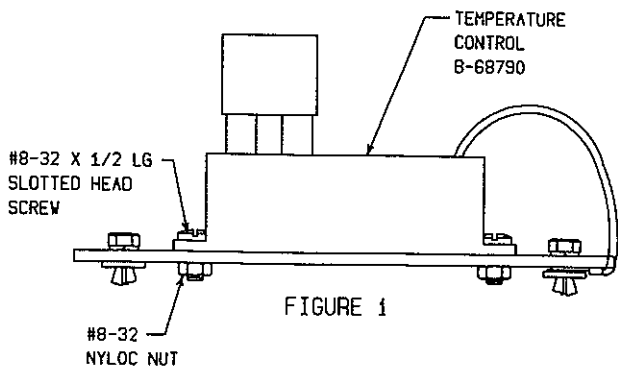

FIGURE 1

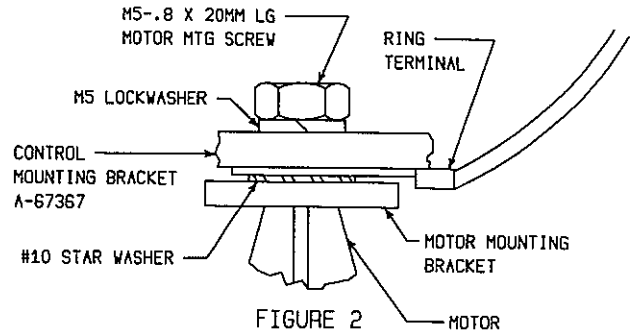

FIGURE 2

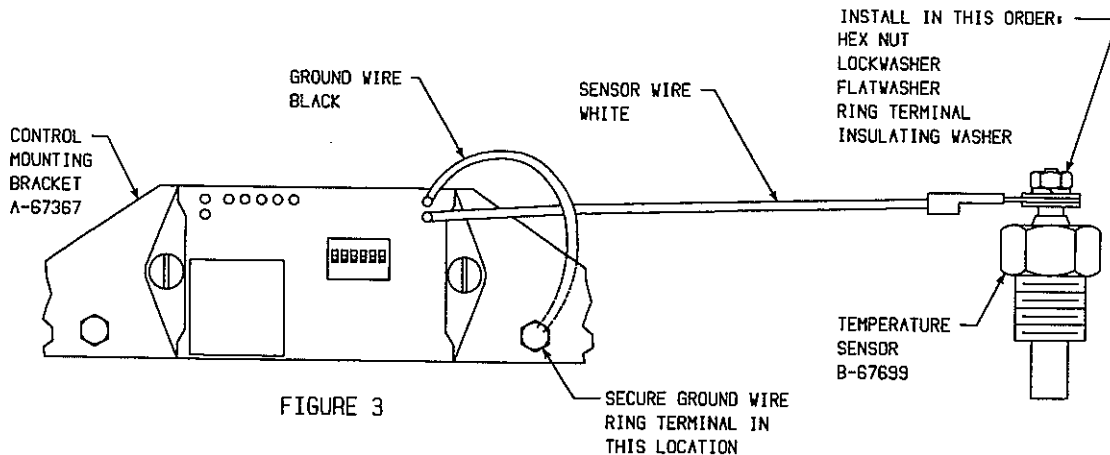

FIGURE 3

**For more information or to purchase these products, please contact:**

**HYDROTHRIFT CORPORATION  
(800) 772-0493**

[www.hydrothrift.com](http://www.hydrothrift.com)  
[sales@hydrothrift.com](mailto:sales@hydrothrift.com)

**DH/DF**  
air cooled