

# BELT GUARD AFTERCOOLERS

- Bolt directly on the existing belt guard (some additional support may be required)
- All steel manifolds with sturdy copper tubes and aluminum fins
- Unique turbulator inside each cooling tube assures maximum performance in a compact size

Model No.	Max. S.C.F.M.*	Weight - LBS.
M-15-76946	20	8
M-20-76785	35	11
M-25-76878	75	19
M-30-76941	100	25

EASY TO INSTALL

RUGGED CONSTRUCTION

SOLID PERFORMANCE

BELT GUARD

air cooled

## MATERIALS

**Tubes** - Copper

**Fins** - Aluminum

**Turbulators** - Steel

**Manifolds** - Steel

## RATINGS

**Pressure rating** - 300 psi

**Operating temperature** - 350°F

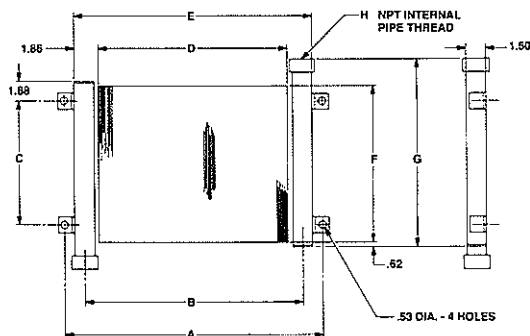

\*Ratings are based on a 250°F inlet temperature, 100 PSIG, and 500 FPM air face velocity across the ambient side of the aftercooler. Maximum pressure drop is 3 PSI or less—all models. 25°F approach temperature.

Model No.	A	B	C	D	E	F	G	H N.P.T.
M-15-76946	19.72	16.72	5.50	14.50	18.22	8.00	10.62	1.00
M-20-76785	19.72	16.72	9.50	14.50	18.22	12.00	14.62	1.00
M-25-76878	25.72	22.72	15.50	20.50	24.22	18.00	20.62	1.00
M-30-76941	24.72	21.72	21.50	19.50	23.22	24.00	26.56	1.25

All dimensions are inches. We reserve the right to make reasonable design changes without notice.