

AIR COOLED SIDE BY SIDE/ACOC SERIES

VERTICAL AIR FLOW

COMPACT DESIGN

LIGHT WEIGHT

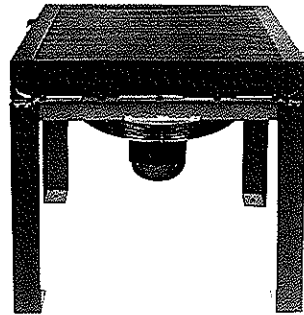

- Compact, high performance all aluminum core assembly
- Designed specifically for rotary screw compressors
- Ideal for converting water cooled units to air cooled. Eliminates high water and sewer costs. Eliminates corrosion problems associated with water cooled units.
- Vertical air flow works well for heat recovery.
- State-of-the-art heat transfer technology.

MAINTENANCE

Periodic cleaning of the fins with compressed air is needed to remove the accumulation of dirt and dust. Check the automatic drain on the separator (not included) periodically.

If the inside of the tubes need to be cleaned of oil and carbon, use a chlorinated solvent. Do not use strong solvents. Do not use acids or caustic cleaners.

MATERIALS

Legs - Steel with baked enamel finish
Shroud - Steel
Core - Aluminum

Fan - Aluminum hub, Plastic blades
Motor - TEFC

RATINGS

Maximum operating pressure - 250 psig
Maximum operating temperature - 350°F

air cooled
ACOC

HOW TO ORDER

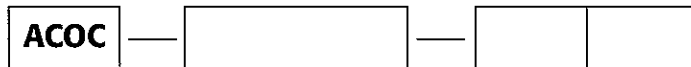

MODEL SERIES

UNIT SIZE SELECTED

MOTOR SPECIFICATION

- 0 = NO MOTOR (INCLUDES FAN BLADE AND FAN GUARD)
- 2 = SINGLE PHASE
- 3 = THREE PHASE

ELECTRIC MOTOR AND FAN DATA

Model	Fan CFM	Motor H.P.	Voltage	Phase	Full Load Amps 230V	Hz	RPM	Nema Frame	Thermal Over-load	Net Weight Lbs.	Approx. Shipping Wt. (Lbs.)
ACOC-400	2200 1825/2200	1.0	115/208-230 208-230/460 ③	1 3	6.0 3.6/3.2	60 ② 50/60	3450 2850/3450	56C	No	105	136
ACOC-725	3600 3025/3600	1.5	115/208-230 208-230/460 ③	1 3	8.5 4.8/4.2	60 ② 50/60	3450 2850/3450			149	155
ACOC-950	4700	1.5	115/208-230 208-230/460	1 3	8.6 4.6	60	1740	145TC		223	280
ACOC-1200	7000	5.0	230	1	23.0			184TC		297	410
		3.0	208-230/460	3	8.8			182TC		345	495
ACOC-1600	9700	5.0	208-230/460	3	13.4			184TC		495	530
ACOC-2000	11000	7.5	230/460		19.6			213TC		522	540
ACOC-2500	14000				24.8			215TC		655	780
ACOC-3000	17500	10.0	230/460		24.8			215TC		690	820
ACOC-3500	17500										

All motors shown are TEFC—Other motor options available upon request.

1. Published electrical ratings are approximate and may vary because of motor brand. Actual ratings are on motor nameplate. 2. May also be operated at 50 Hz. Consult factory for details.
3. 50 Hz voltage: 190 - 200 - 208 - 220/380 - 400 - 415 - 440 4. 50 Hz voltage: 190 - 208/380 - 415

SELECTION PROCEDURE

- Step 1. Determine the Air Compressor's motor horsepower.**
- Step 2. Enter the chart** at the motor horsepower to select the correct model.
- Step 3. Check the aftercooler SCFM.** The SCFM of air discharged from the air compressor must be equal to or less than the value in the chart for the model selected. If it is not, choose a larger model. If the SCFM is unknown, multiply the air compressor's motor horsepower by 4.5 to determine the SCFM capacity required.

Sizing Notes:

- Oil flow is .45 GPM/HP.
- Oil pressure drop - 15 psi or less
- Oil heat transfer based on 100°F E.T.D.
(E.T.D. = Entering Temperature Difference)
(E.T.D. = Oil in Temperature - Ambient Air Temperature)
- Air aftercooler pressure drop - 3 psi or less.
- E.T.D. Temperature Correction Factor: $HP_{chart} = HP_{compressor} \times \frac{100}{Desired\ E.T.D.}$

RECOMMENDED TYPICAL INSTALLATION

NOTES:

- A 3-way thermostatic valve is recommended to by-pass the cold oil around the heat exchanger during start up.
- Support piping as needed. Flexible connectors must be properly installed to validate warranty.
- Cooler not to be operated in ambient temperatures below 35°F (1°C).
- The fan cannot be cycled.
- ACOC coolers operated outdoors must be protected from weather. Consult factory for recommendations.
- If ductwork or additional static resistance is added to the cooler airstream, an auxiliary air mover may be required.

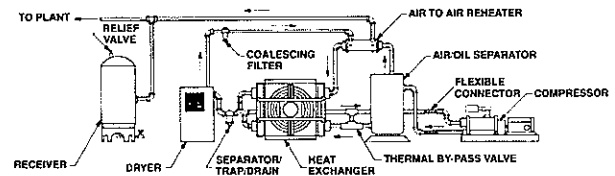

Bottom view of cooler shown to better illustrate piping.

Aftercooler Maximum SCFM with 100 PSI Air & A 15°F Approach Temperature

Compressor H.P.	Model	Maximum SCFM
15-35	ACOC-400	175
40-55	ACOC-725	275
60-85	ACOC-950	425
90-120	ACOC-1200	600
125-155	ACOC-1600	775
160-225	ACOC-2000	1125
230-275	ACOC-2500	1375
280-325	ACOC-3000	1625
330-360	ACOC-3500	1800

DIMENSIONS

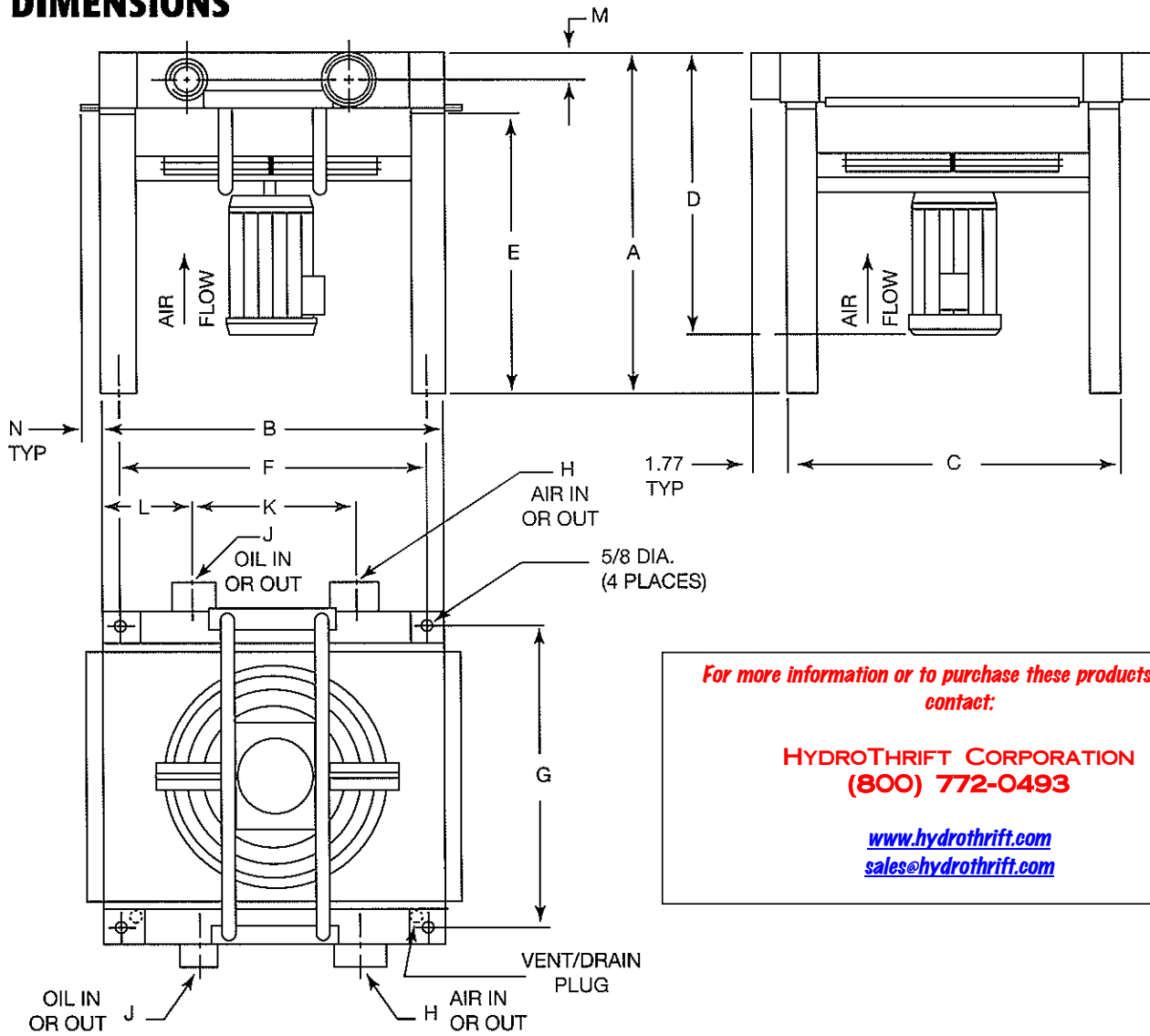

For more information or to purchase these products, please contact:

HYDROTHRIFT CORPORATION
(800) 772-0493

www.hydrothrift.com
sales@hydrothrift.com

air cooled
ACOC

Model	A	B	C	D Approx.	E	F	G	H NPT	J NPT	K	L	M	N	
ACOC-400	34.20	17.96	22.68	20.86	30.00	13.96	18.68	1.50	1.00	8.30	5.08	1.85		
ACOC-725		22.37	30.56			18.37	26.56			10.54	6.33			
ACOC-950	36.01	26.78	37.24	23.62	22.78	33.24	2.00	1.25	12.67	7.63	16.82	10.08	2.76	1.25
ACOC-1200			41.19	25.51										
ACOC-1600		34.89	27.51	30.89	47.04	2.50	1.50	20.80	12.84					
ACOC-2000		37.88	51.04							33.88	47.04			
ACOC-2500		43.70	49.07	48.52	47.04	3.00	2.00	25.09	15.42					
ACOC-3000		52.52	51.04							48.52	47.04			
ACOC-3500		56.30	51.04	30.51	52.30	4.00	2.50	26.43	18.44					

Specifications and dimensions subject to change without notice.