

# WATER COOLED INDUSTRIAL/EK SERIES

water cooled  
EK/K/EC/EKT

**COMPACT SIZE**

**HIGH EFFICIENCY FINNED BUNDLE DESIGN**

**LOW COST**

**OPTIONAL PATENTED BUILT-IN SURGE-CUSHION RELIEF BYPASS**

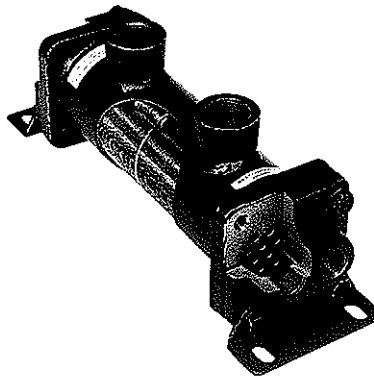

Cutaway view shows high performance copper tube/aluminum fin cooling chamber with patented SURGE-CUSHION® relief bypass valve.

- Heat Removal up to 400 Horsepower (300 kW)
- Oil Flow rates up to 80 U.S. GPM (300 Liters/min.)
- Large Oil Connections for Minimum Entering and Exiting Flow Restriction
- Removable End Bonnets for easy tube cleaning
- Mounting Brackets Designed so that Cooler can be Rotated in 90° Increments
- High Pressure Ratings
- Complete Line of Accessories Available



## MATERIALS

**Shell** - Steel  
 **Tubesheets** - Steel  
**Baffles** - Steel  
 **Mounting Brackets** - Steel  
**Gaskets** - Nitrile Rubber/Cellulose Fiber

**Nameplate** - Aluminum Foil  
**Tubes** - Copper  
**Fins** - Aluminum  
**End Caps** - Grey Iron

## RATINGS

**Operating pressure** - 500 psi  
**Test pressure** - 150 psi  
**Operating temperature** - 250°F

## SURGE-CUSHION (Option)

The SURGE-CUSHION® is a protective device (patented) designed to internally bypass a portion of the oil flow during cold start conditions, or when sudden flow surges temporarily exceed the maximum flow allowed for a given cooler. This device may replace an external bypass valve, but it is not intended to bypass the total oil flow.

## MAXIMUM FLOW RATES

UNIT SIZE	SHELL SIDE GPM	TUBE SIDE GPM		
		ONE PASS	TWO PASS	FOUR PASS
500	20	13	6	N/A
700	60	24	12	6
1000	80	56	28	14

Incorrect installation can cause premature failure.

## HOW TO ORDER



EK  
EKS  
EKM  
EKF  
EKFM

MODEL SIZE SELECTED

BAFFLE SPACING ◆

TUBESIDE PASSES

O - ONE PASS  
T - TWO PASS  
F - FOUR PASS

SURGE CUSHION

BLANK - NO RELIEF BYPASS  
R - RELIEF BYPASS

COOLING TUBE MATERIAL

BLANK - COPPER  
CN - CuNi

EK = NPT Oil connections; NPT Water connections.

EKS = SAE O-Ring Oil connections; NPT Water connections.

EKM = BSPP Oil connections; BSPP Water connections.

EKF = SAE 4 Bolt Flange (Tapped SAE) Oil connections; NPT Water connections.

EKFM = SAE 4 Bolt Flange (Tapped Metric) Oil connections; BSPP Water connections.

◆EK-1036 and EK-1048 Models only.

# DIMENSIONS

## ONE PASS

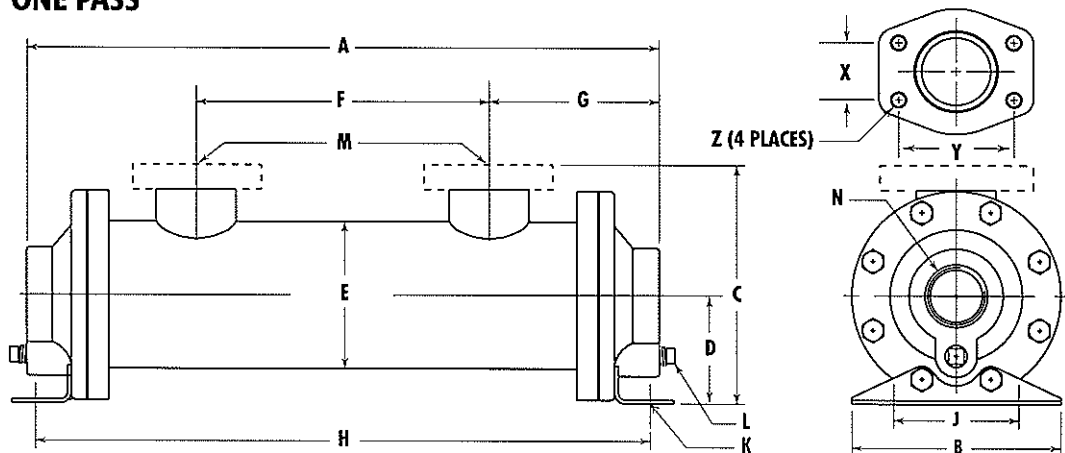

<b>FLANGE SIZE</b>	1-1/2	2
<b>X</b>	1.41	1.69
<b>Y</b>	2.75	3.06
<b>EKF Z</b>	1/2 - 13 UNC-2B	
<b>EKFM Z</b>	M-12	

MODEL	A	B	C		D	E	F	G	H	J	K	L					M			N
			NPT / BSPP SAE O-RING	SAE FLANGE								NPT BSPP	NPT	SAE O-RING	SAE FLANGE	BSPP	NPT BSPP			
EK-505	7.38	3.5 MAX. WIDTH	3.74	N/A	1.62	2.55 DIA.	2.19	2.59	7.44	2.50	.34 x .62 SLOT	N/A	3/4	#8 3/4-16 UNF-2B	N/A	3/4	1/2	3/4	3/4	
EK-508	10.38						3.85		10.44											
EK-510	12.38						5.85		12.44											
EK-512	14.38						7.85		14.44											
EK-514	16.38						9.85		16.44											
EK-518	20.38						13.85		20.44											
EK-524	26.38						19.85		26.44											
EK-536	38.38						31.85		38.44											
EK-708	11.12	5.0 MAX. WIDTH	5.47	5.71	2.59	3.52 DIA.	3.00	4.07	10.71	3.00	.44 x .75 SLOT	1/4	1 1/2	#24 1 7/8-12 UN-2B	1 1/2	1 1/2	1 1/2	1 1/4		
EK-712	15.12						7.00		14.71											
EK-714	17.12						9.00		16.71											
EK-718	21.12						13.00		20.71											
EK-724	27.12						19.00		26.71											
EK-736	39.12						31.00		38.71											
EK-1012	15.33	6.5 MAX. WIDTH	7.64	8.28	4.00	5.05 DIA.	6.18	4.57	15.45	4.00	.44 x 1.00 SLOT	2	2	2	2	2	1 1/2			
EK-1014	17.33						8.18		17.45											
EK-1018	21.33						12.18		21.45											
EK-1024	27.33						18.18		27.45											
EK-1036	39.33						30.18		39.45											
EK-1048	51.33						42.18		51.45											

NOTE: We reserve the right to make reasonable design changes without notice. All dimensions are in inches.

# DIMENSIONS

## TWO PASS

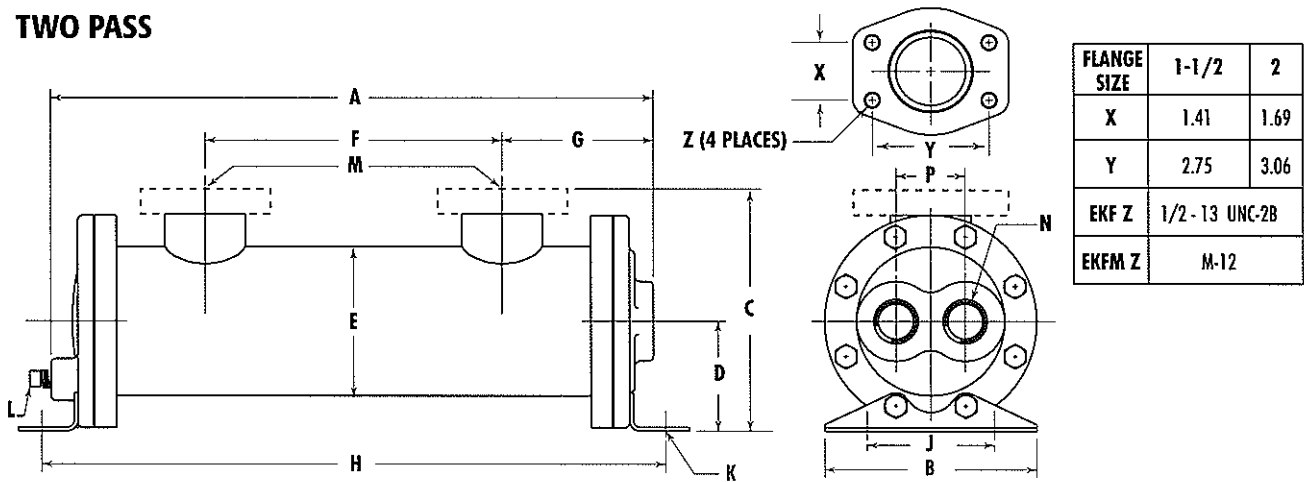

water cooled  
EK/K/EC/EKT

MODEL	A	B	C		D	E	F	G	H	J	K	L		M			N		P
			NPT / BSPP SAE O-RING	SAE FLANGE								NPT BSPP	NPT	SAE O-RING	SAE FLANGE	BSPP	HPT BSPP		
EK-505	7.38	3.5 MAX. WIDTH	3.74	N/A	1.62	2.55 DIA.	2.19	3.26	7.44	2.50	.34 x .62 SLOT	N/A	1/2	#8 3/4-16 UNF-2B	N/A	3/4	3/8	1.12	
EK-508	10.38		3.85				10.44												
EK-510	12.38		5.85				12.44												
EK-512	14.38		7.85				14.44												
EK-514	16.38		9.85				16.44												
EK-518	20.38		13.85				20.44												
EK-524	26.38		19.85				26.44												
EK-536	38.38		31.85				38.44												
EK-708	10.19	5.0 MAX. WIDTH	5.47	5.71	2.59	3.52 DIA.	3.00	3.57	10.71	3.00	.44 x .75 SLOT	1/4	1 1/2	#24 17/8-12 UN-2B	1 1/2	1 1/2	3/4	1.62	
EK-712	14.19						7.00		14.71										
EK-714	16.19						9.00		16.71										
EK-718	20.19						13.00		20.71										
EK-724	26.19						19.00		26.71										
EK-736	39.19						31.00		38.71										
EK-1012	14.58	6.5 MAX. WIDTH	7.64	8.28	4.00	5.05 DIA.	6.18	4.45	15.45	4.00	.44 x 1.00 SLOT	2	2	2	2	1.0	2.38		
EK-1014	16.58						8.18		17.45										
EK-1018	20.58						12.18		21.45										
EK-1024	26.58						18.18		27.45										
EK-1036	38.58						30.18		39.45										
EK-1048	50.58						42.18		51.45										

NOTE: We reserve the right to make reasonable design changes without notice. All dimensions are in inches.

# DIMENSIONS

## FOUR PASS

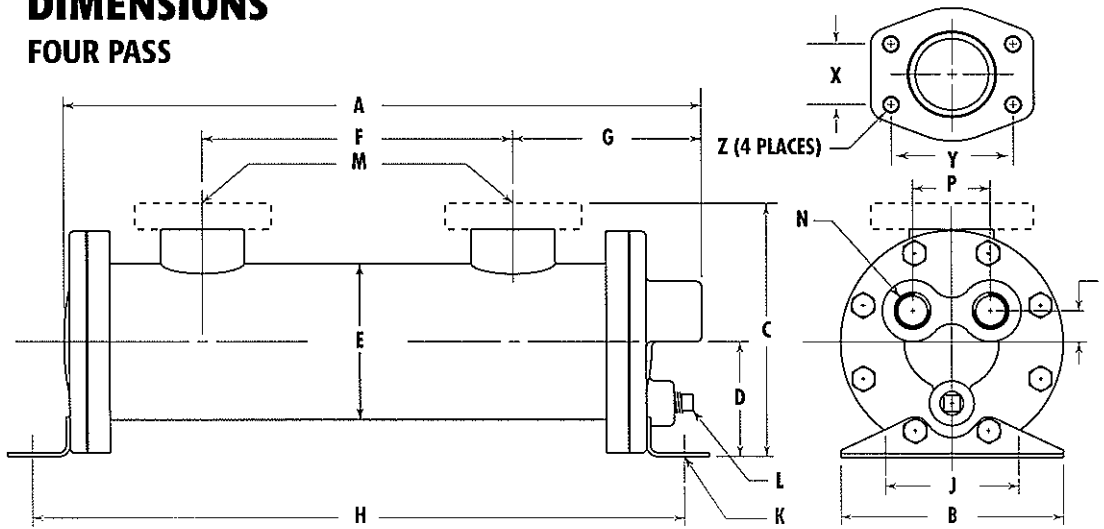

FLANGE SIZE	1-1/2	2
X	1.41	1.69
Y	2.75	3.06
EKF Z	1/2 - 13 UNC-28	
EKFM Z	M-12	

MODEL	A	B	C		D	E	F	G	H	J	K	M					N		P	R
			HPT / BSPP SAE O-RING	SAE FLANGE								L	HPT	SAE O-RING	SAE FLANGE	BSPP	HPT BSPP			
EK-708	10.37	5.0 MAX. WIDTH	5.47	5.71	2.59	3.52 DIA.	3.00	4.25	10.71	3.00	.44 x .75 SLOT	1/4	1 1/2	#24 17/8-12 UN-28	1 1/2	1/2	1.75	.70		
EK-712	14.37						7.00		14.71											
EK-714	16.37						9.00		16.71											
EK-718	20.37						13.00		20.71											
EK-724	26.37						19.00		26.71											
EK-736	38.37						31.00		38.71											
EK-1012	14.33	6.5 MAX. WIDTH	7.64	8.28	4.00	5.05 DIA.	6.18	4.45	15.45	4.00	.44 x 1.00 SLOT	2	2	2	3/4	2.50	.89			
EK-1014	16.33						8.18		17.45											
EK-1018	20.33						12.18		21.45											
EK-1024	26.33						18.18		27.45											
EK-1036	38.33						30.18		39.45											
EK-1048	50.33						42.18		51.45											

NOTE: We reserve the right to make reasonable design changes without notice. All dimensions are in inches.

## SELECTION PROCEDURE

Performance Curves are based on 100SSU oil leaving the cooler 40°F higher than the ambient air temperature used for cooling. This is also referred to as a 40°F approach temperature.

### Step 1. Determine the Heat Load.

This will vary with different systems, but typically coolers are sized to remove 25 to 50% of the input nameplate horsepower. (Example: 100 HP Power Unit x .33 = 33 HP Heat load.)

If BTU/Hr. is known:  $HP = \frac{BTU/Hr}{2545}$

### Step 2. Determine Approach Temperature.

Desired oil leaving cooler °F - Water Inlet temp. °F = Actual Approach (Max. reservoir temp.)

### Step 3. Determine Curve Horsepower Heat Load.

Enter the information from above:

Horsepower heat load x  $\frac{40}{\text{Actual Approach}}$  x Viscosity Correction A = Curve Horsepower

### Step 4. Enter curves at oil flow through cooler and curve horsepower.

Any curve above the intersecting point will work.

### Step 5. Determine Oil Pressure Drop from Curves:

● = 5 PSI; ■ = 10 PSI; ▲ = 20 PSI. Multiply pressure drop from curve by correction factor B found on oil viscosity correction curve.

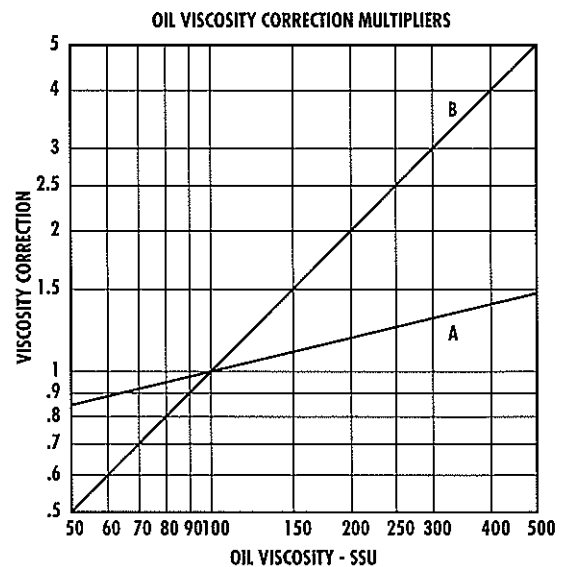

# PERFORMANCE CURVES

## 1:1 Oil to Water Ratio - HIGH WATER USAGE

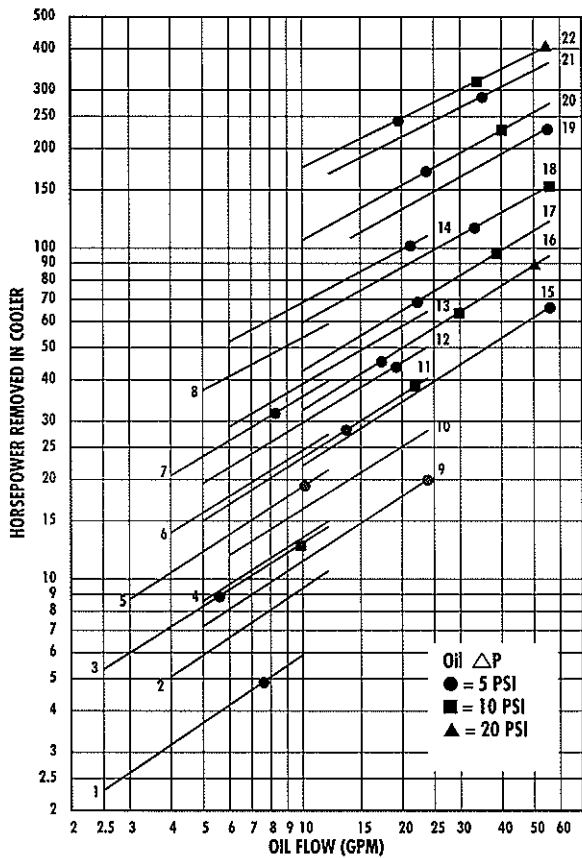

### MODELS

1. EK-505-0
2. EK-508-0
3. EK-510-0
4. EK-512-0
5. EK-514-0
6. EK-518-0
7. EK-524-0
8. EK-536-0
9. EK-708-0
10. EK-712-0
11. EK-714-0
12. EK-718-0
13. EK-724-0
14. EK-736-0
15. EK-1012-0
16. EK-1014-0
17. EK-1018-0
18. EK-1024-0
19. EK-1036-9-0
20. EK-1036-6-0
21. EK-1048-8-0
22. EK-1048-6-0

NET	WEIGHTS (LBS.)	APPROX. SHIPPING
6	7	7
7	8	8
8	9	9
9	10	10
10	11	11
11	12	12
13	14	14
17	18	18
15	16	16
18	19	19
19	20	20
22	23	23
26	28	28
34	36	36
35	37	37
38	40	40
42	45	45
50	55	55
67	85	85
67	85	85
78	95	95
78	95	95

water cooled  
EK/K/EC/EKT

# PERFORMANCE CURVES

## 2:1 Oil to Water Ratio - MEDIUM WATER USAGE

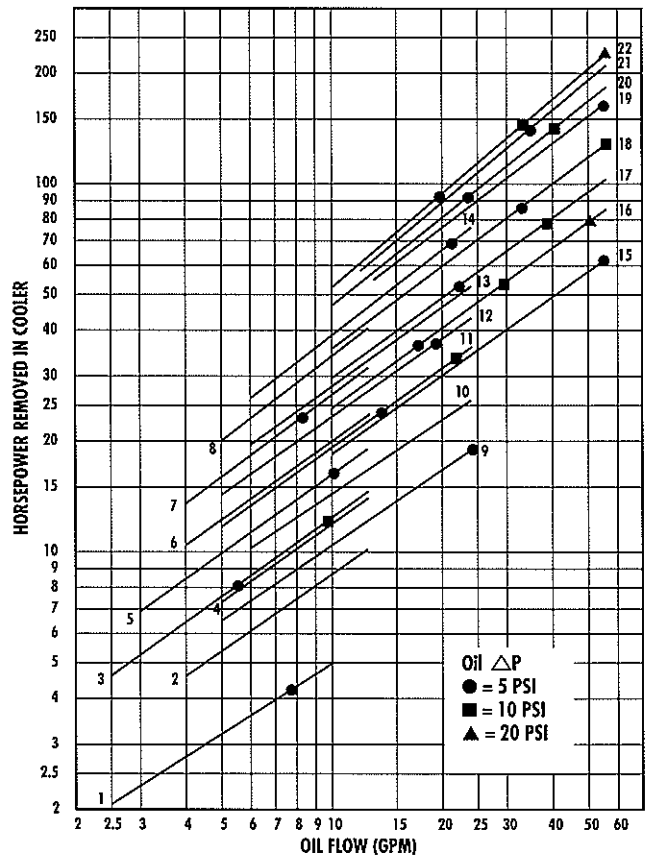

### MODELS

1. EK-505-T
2. EK-508-T
3. EK-510-T
4. EK-512-T
5. EK-514-T
6. EK-518-T
7. EK-524-T
8. EK-536-T
9. EK-708-T
10. EK-712-T
11. EK-714-T
12. EK-718-T
13. EK-724-T
14. EK-736-T
15. EK-1012-T
16. EK-1014-T
17. EK-1018-T
18. EK-1024-T
19. EK-1036-9-T
20. EK-1036-6-T
21. EK-1048-8-T
22. EK-1048-6-T

### NET

- 6
- 7
- 8
- 9
- 10
- 11
- 12
- 13
- 15
- 18
- 19
- 22
- 26
- 34
- 35
- 38
- 42
- 50
- 67
- 67
- 78
- 78

### WEIGHTS (LBS.) APPROX. SHIPPING

- 7
- 8
- 9
- 10
- 11
- 12
- 14
- 18
- 16
- 19
- 20
- 23
- 28
- 36
- 37
- 40
- 45
- 55
- 85
- 85
- 95
- 95

# PERFORMANCE CURVES

## 4:1 Oil to Water Ratio - LOW WATER USAGE

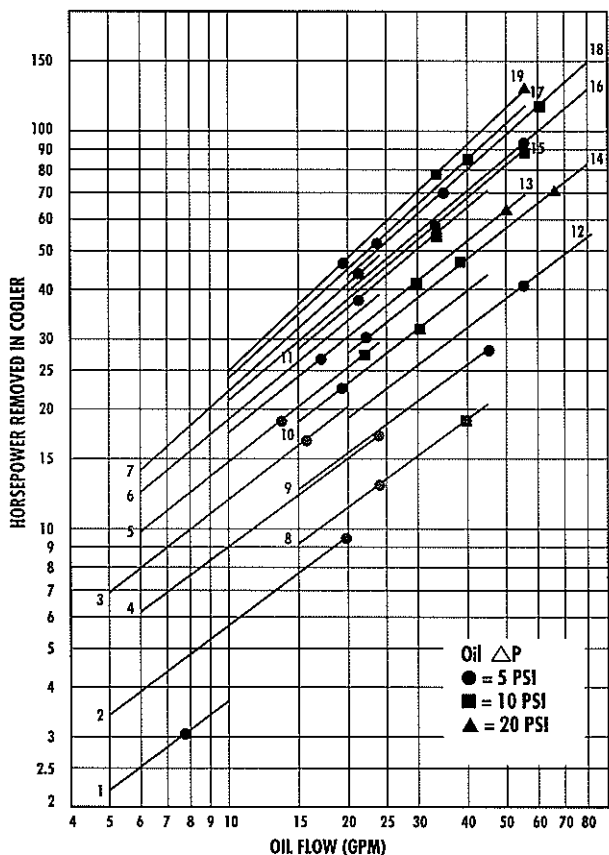

MODELS	NET	WEIGHTS (LBS.) APPROX. SHIPPING
1. EK-505-T	6	7
2. EK-508-T	7	8
3. EK-518-T	11	12
4. EK-708-F	15	16
5. EK-714-F	19	20
6. EK-724-F	26	28
7. EK-736-F	34	36
8. EK-708-T	15	16
9. EK-712-T	18	19
10. EK-718-T	22	23
11. EK-736-T	34	36
12. EK-1012-T	35	37
13. EK-1014-F	38	40
14. EK-1018-T	42	45
15. EK-1024-F	50	55
16. EK-1036-9-T	67	85
17. EK-1036-6-F	67	85
18. EK-1048-8-T	78	95
19. EK-1048-6-F	78	95

# PERFORMANCE CURVES

## 7:1 Oil to Water Ratio - LOWER WATER USAGE

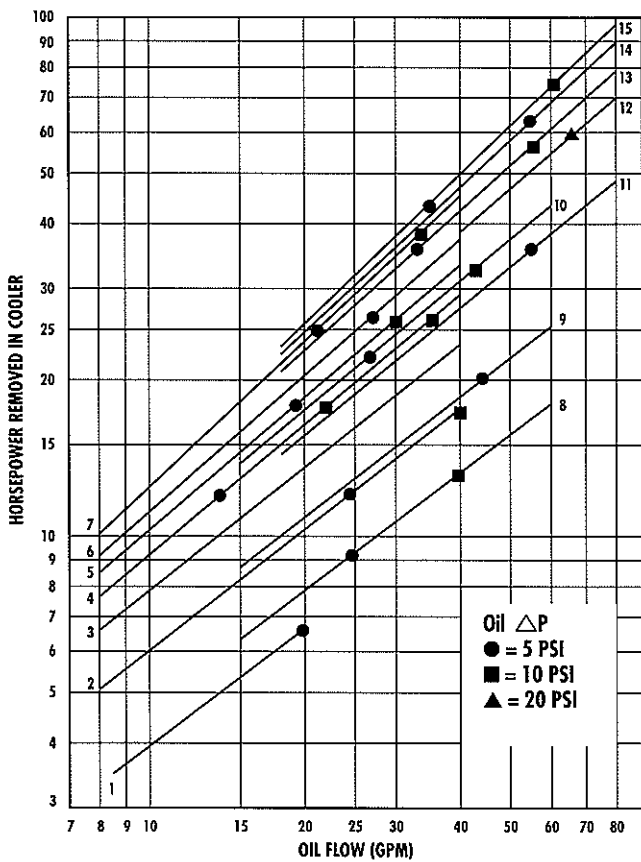

MODELS	NET	WEIGHTS (LBS.) APPROX. SHIPPING
1. EK-508-T	7	8
2. EK-708-F	15	16
3. EK-712-F	18	19
4. EK-714-F	19	20
5. EK-718-F	22	23
6. EK-724-F	26	28
7. EK-736-F	34	36
8. EK-708-T	15	16
9. EK-712-T	18	19
10. EK-724-T	26	28
11. EK-1012-F	35	37
12. EK-1018-F	42	45
13. EK-1024-F	50	55
14. EK-1036-9-F	67	85
15. EK-1048-8-F	78	95

# PERFORMANCE CURVES

## 10:1 Oil to Water Ratio - LOWEST WATER USAGE

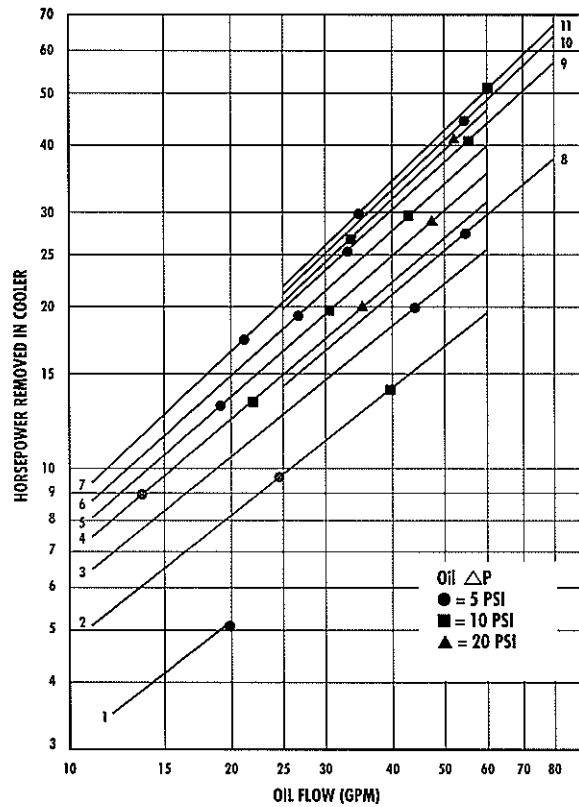

MODELS
1. EK-508-T
2. EK-708-F
3. EK-712-F
4. EK-714-F
5. EK-718-F
6. EK-724-F
7. EK-736-F
8. EK-1012-F
9. EK-1024-F
10. EK-1036-9-F
11. EK-1048-8-F

NET WEIGHTS (LBS.)	APPROX. SHIPPING WEIGHTS
7	8
15	16
18	19
19	20
22	23
26	28
34	36
35	37
50	55
67	85
78	95

water cooled  
EK/K/EC/EKT

System Horsepower	HP Heat Load	Minimum Required GPM Oil Flow	Minimum Required GPM Water Flow	Heat Exchanger Model Number
3	.9	1	1	EK-505-T
5	1.5	2		
7.5	2.25	3	1.5	EK-512-T
10	3			
15	4.5			
20	6	6	3	EK-712-T
25	7.5	7.5	4	
30	9	9	4.5	
40	12	12	6	EK-1012-T
50	15	15	7.5	
60	18	18	9	
75	22.5	23	12	
100	30	30	15	

## RECIRCULATION LOOP WATER COOLED HYDRAULIC OIL COOLERS

### BASIS:

- 40°F Entering temperature difference (Maintain reservoir 40°F above the incoming water temperature)
- Heat removal 30% of input horsepower
- Hydraulic system flow (GPM) x 3 = Gallons; reservoir size
- 1 GPM cooler flow per HP heat to be removed
- Turn-over reservoir 3-4 times per hour
- Maximum flows:

# WATER COOLED EXTENDED SURFACE/K SERIES

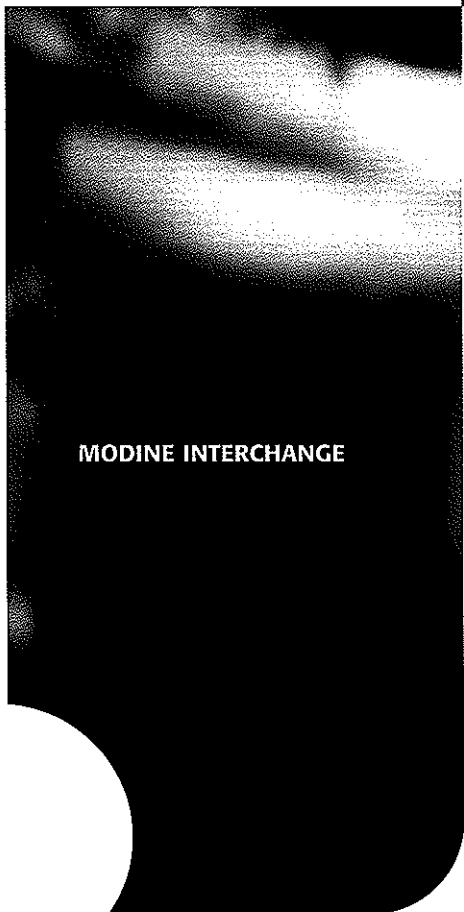

MODINE INTERCHANGE

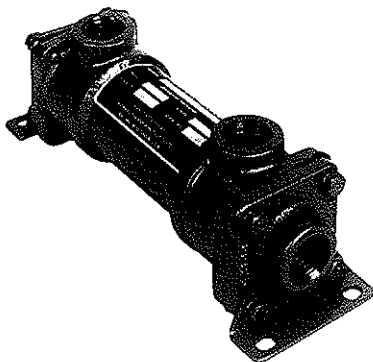

### OPTIONS:

- SAE Internal "O" Ring Ports
- Shell Side

### MATERIALS

- Shell** - Steel
- Tubes** - Copper
- Baffles** - Steel
- Mounting Brackets** - Steel
- Gaskets** - Non Asbestos Nitrile  
Rubber/Cellulose Fiber

- Nameplate** - Aluminum Foil
- Fins** - Aluminum
- End Hubs** - Cast Malleable Iron
- End Bonnets** - Cast Iron
- Headers** - Cast Malleable Iron

### RATINGS

<b>Pressure ratings (p.s.i.) K-500 &amp; K-700 Series</b>		
<b>Operating</b>	<b>Test</b>	
500	550	Shells
150	225	Tubes
<b>Pressure ratings (p.s.i.) K-1000 Series</b>		
<b>Operating</b>	<b>Test</b>	
400	450	Shells
150	225	Tubes
<b>Operating temperature - 350°F</b>		

### HOW TO ORDER





# DIMENSIONS

## ONE PASS

### K-500, 700 SERIES

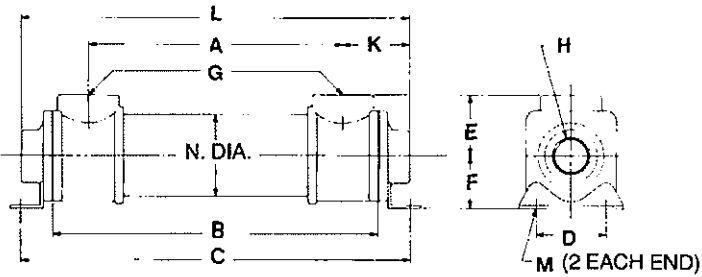

MODEL	L	H N.P.T.	K
K-508-0	10.19	.75	2.22
K-512-0	14.19		
K-514-0	16.19		
K-518-0	20.19		
K-708-0	10.69	1.25	2.84
K-712-0	14.69		
K-714-0	16.69		
K-718-0	20.69		
K-1012-0	17.12	2.00	4.31
K-1014-0	19.12		
K-1018-0	23.12		
K-1024-0	29.12		

### K-1000 SERIES

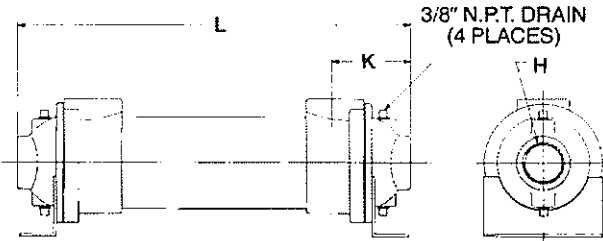

# DIMENSIONS

## TWO PASS

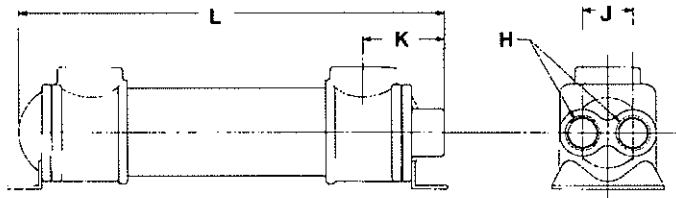

MODEL	L	H N.P.T.	J	K
K-708-T	10.69	1.00	2.00	2.84
K-712-T	14.69			
K-714-T	16.69			
K-718-T	20.69			
K-1012-T	17.12	1.50	2.38	4.31
K-1014-T	19.12			
K-1018-T	23.12			
K-1024-T	29.12			

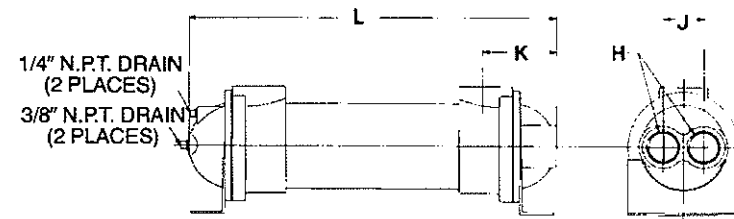

MODEL	A	B	C	D	E	F	G N.P.T.	M	N DIA.	WEIGHT (LBS.)	MODEL
K-508	5.75	8.00	10.25	2.50	1.88	1.62	.75	.34 x .50	2.50	7.75	K-508
K-512	9.75	12.00	14.25							8.75	K-512
K-514	11.75	14.00	16.25							9.12	K-514
K-518	15.75	18.00	20.25							10.00	K-518
K-708	5.00	8.00	10.75	3.00	2.62	2.25	1.50	.44 x .75	3.50	15.75	K-708
K-712	9.00	12.00	14.75							18.40	K-712
K-714	11.00	14.00	16.75							19.75	K-714
K-718	15.00	18.00	20.75							21.50	K-718
K-1012	8.50	12.00	15.50	4.00	3.50	4.00	2.00	.44 x 1.00	5.30	42.50	K-1012
K-1014	10.50	14.00	17.50							44.25	K-1014
K-1018	14.50	18.00	21.50							49.00	K-1018
K-1024	20.50	24.00	27.50							57.00	K-1024

MODEL	G SAE (OPTIONAL)
KN-508	#12 1-1/16 - 12
KN-512	
KN-514	
KN-518	#24 1-7/8 - 12
KN-708	
KN-712	
KN-714	
KN-718	#32 2-1/2 - 12
KN-1012	
KN-1014	
KN-1018	
KN-1024	UN-2B

\*K\* Prefix Designates N.P.T. Shell Connections

\*KN\* Prefix Designates

\*SAE\* Internal Thread

\*O\* Ring Shell Connections

NOTE: We reserve the right to make reasonable design changes without notice.

# PERFORMANCE CURVES

## 2:1 Oil to Water Ratio

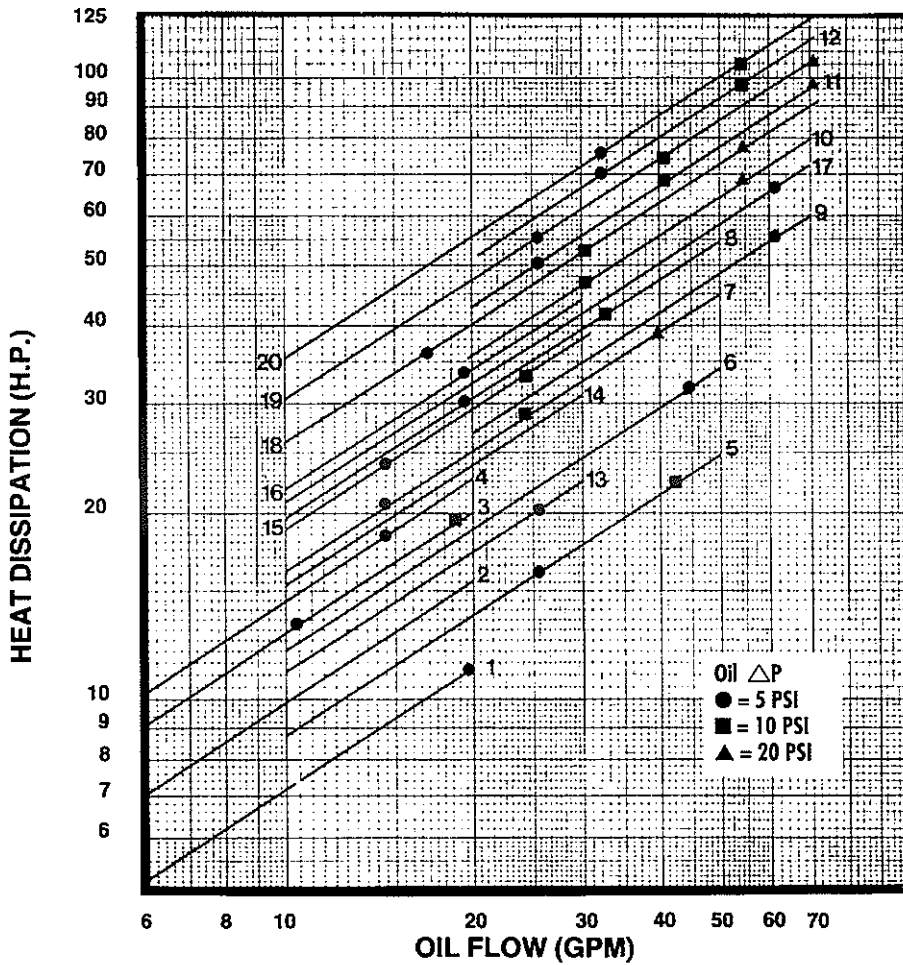

### MODEL CODE

1. K-508-0
2. K-512-0
3. K-514-0
4. K-518-0
5. K-708-0
6. K-712-0
7. K-714-0
8. K-718-0
9. K-1012-0
10. K-1014-0
11. K-1018-0
12. K-1024-0
13. K-708-T
14. K-712-T
15. K-714-T
16. K-718-T
17. K-1012-T
18. K-1014-T
19. K-1018-T
20. K-1024-T

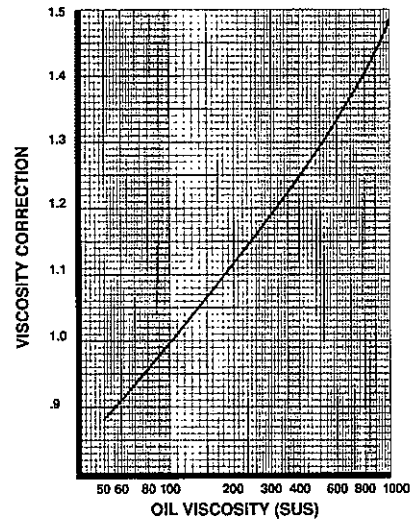

## SELECTION PROCEDURE

Performance Curves are based on 100SSU oil leaving the cooler 40°F higher than the ambient air temperature used for cooling. This is also referred to as a 40°F approach temperature.

### Step 1. Determine the Heat Load.

This will vary with different systems, but typically coolers are sized to remove 25 to 50% of the input nameplate horsepower. (Example: 100 HP Power Unit x .33 = 33 HP Heat load.)

If BTU/Hr. is known:  $HP = \frac{BTU/Hr}{2545}$

### Step 2. Determine Approach Temperature.

Desired oil leaving cooler °F - Water Inlet temp. °F = Actual Approach  
(Max. reservoir temp.)

### Step 3. Determine Curve Horsepower Heat Load.

Enter the information from above:

Horsepower heat load x  $\frac{40}{\text{Actual Approach}}$  x Viscosity Correction A = Curve Horsepower

### Step 4. Enter curves at oil flow through cooler and curve horsepower.

Any curve above the intersecting point will work.

### Step 5. Determine Oil Pressure Drop from Curves:

● = 5 PSI; ■ = 10 PSI; ▲ = 20 PSI. Multiply pressure drop from curve by correction factor found in oil ΔP correction curve.

## MAXIMUM FLOW RATES

Unit Size	Shell Side (GPM)	Tube Side (GPM)	
		O	T
500	20	13	—
700	70	24	12
1000	100	56	28

# PERFORMANCE CURVES

4:1 Oil to Water Ratio

water cooled  
EK/K/EC/EKT

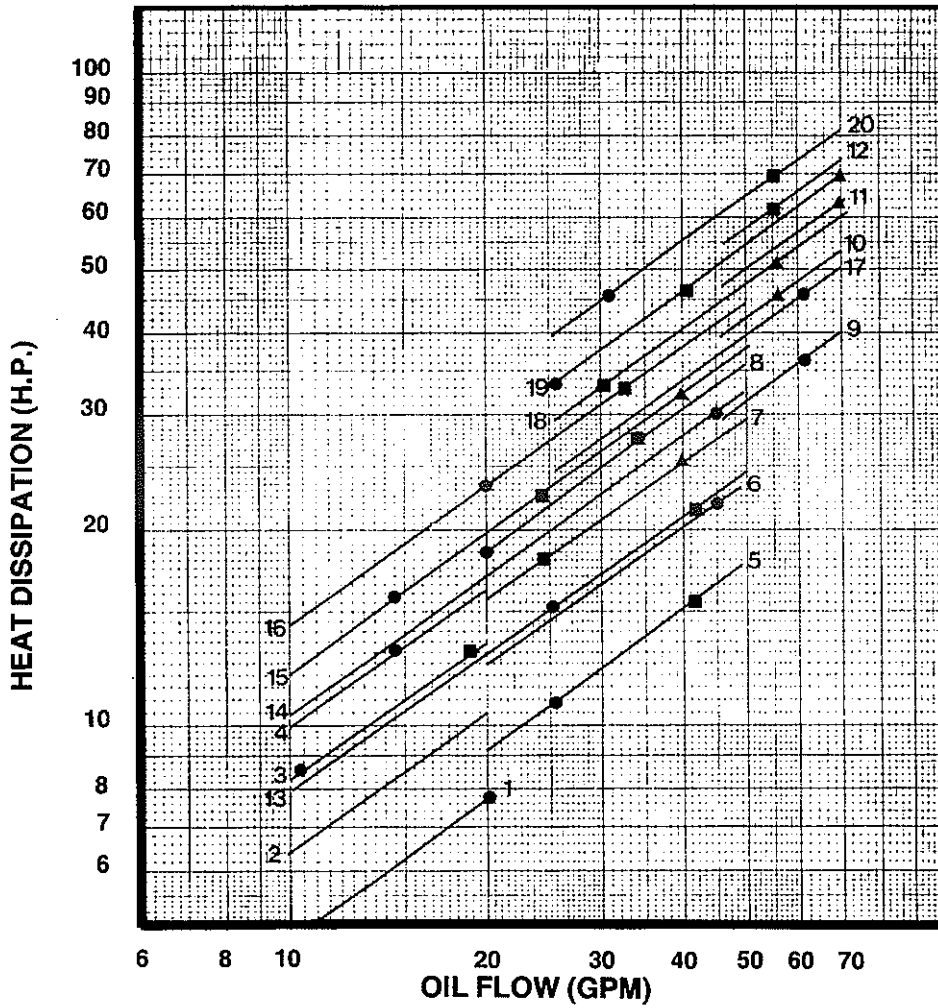

## UNIT CODING

## MODEL

K-714-T

(Example)

Extended Surface Design

Shell Diameter

Effective Tube Length

Tube Side Passes

## PIPING DIAGRAMS

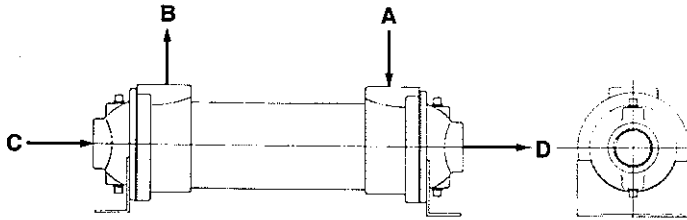

Single Pass Model

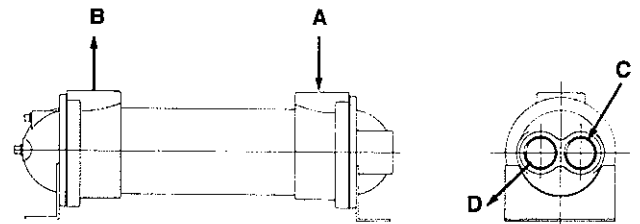

Two Pass Model

- A - Hot fluid to be cooled
- B - Cooled fluid
- C - Cooling water in
- D - Cooling water out

# WATER COOLED INDUSTRIAL/EC SERIES

**RUGGED STEEL SHELL CONSTRUCTION**

**HIGH EFFICIENCY FINNED BUNDLE DESIGN**

**LOW COST**

**OPTIONAL PATENTED BUILT-IN SURGE-CUSHION BYPASS**

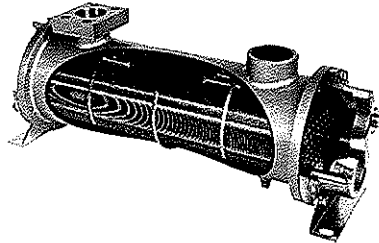

Cutaway view shows high performance copper tube/aluminum fin cooling chamber with patented SURGE-CUSHION® relief bypass valve, and optional flange connections.

- End bonnets removable for easy tube cleaning
- Mounting brackets included—may be rotated for simple installation
- NPT, SAE, BSPP, BSPT or flange connections
- Optional type 316 stainless steel or 90/10 copper-nickel components available



## MATERIALS

**Shell** - Steel  
**Tubesheets** - Steel  
**Baffles** - Steel  
**Mounting Brackets** - Steel  
**Gaskets** - Nitrile Rubber/Cellulose Fiber

**Nameplate** - Aluminum Foil  
**Tubes** - Copper  
**Fins** - Aluminum  
**End Caps** - Grey Iron

## RATINGS

**Operating pressure** - 300 psi  
**Test pressure** - 150 psi  
**Operating temperature** - 300°F

## SURGE-CUSHION (Option)

The SURGE-CUSHION® is a protective device (patented) designed to internally bypass a portion of the oil flow during cold start conditions, or when sudden flow surges temporarily exceed the maximum flow allowed for a given cooler. This device may replace an external bypass valve, but it is not intended to bypass the total oil flow.

## MAXIMUM FLOW RATES

UNIT SIZE	SHELL SIDE GPM	TUBE SIDE GPM		
		ONE PASS	TWO PASS	FOUR PASS
1000	70	65	32	16
1200	120	120	60	30
1700	250	220	110	65

Incorrect installation can cause premature failure.

## HOW TO ORDER

EC	MODEL SIZE SELECTED	BAFFLE SPACING	TUBESIDE PASSES	SURGE CUSHION	COOLING TUBE MATERIAL	END BONNET MATERIAL	TUBESHEET MATERIAL	ZINC ANODES
ECS			O - ONE PASS	BLANK - NO VALVE	BLANK - COPPER	BLANK - CAST IRON	BLANK - STEEL	BLANK - NONE
ECM			T - TWO PASS	R - VALVE INCLUDED	CN - CuNi	B - BRONZE	W - CuNi	Z - ZINC ANODES
ECF			F - FOUR PASS		SS - 316	SB - 316	S - 316	
ECFM					STAINLESS STEEL	STAINLESS STEEL	STAINLESS STEEL	

EC = NPT Oil connections; NPT Water connections. ECS = SAE O-Ring Oil connections; NPT Water connections. ECM = BSPP Oil connections; BSPP Water connections. ECF = SAE 4 Bolt Flange (Tapped SAE) Oil connections; NPT Water connections. ECFM = SAE 4 Bolt Flange (Tapped Metric) Oil connections; BSPP Water connections.

# DIMENSIONS

## ONE PASS

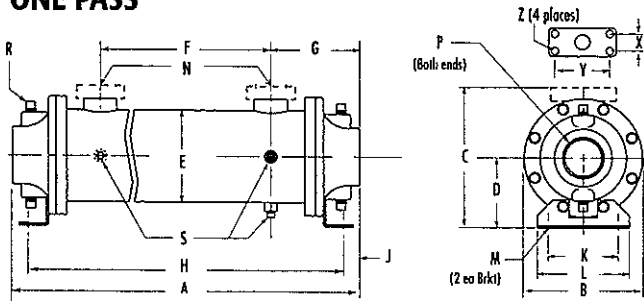

SAE Flange Size	X	Y	Z
1-1/2	1.41	2.75	1/2 - 13
2	1.69	3.06	UNC-2B
3	2.44	4.19	5/8 - 11 UNC 2B

MODEL	A	B	C		D	E	F	G	H	J	K	L	M	N		P	R	S
			NPT / BSPP SAE O-RING	SAE FLANGE										NPT / BSPP FLANGE	SAE O-RING			
EC-1014	20.22	6.75 DIA.	7.75	8.00	4.00	5.25 DIA.	10.12	5.05	18.38	.92	4.00	5.25	.50 x .75 SLOT	1-1/2	#24 SAE	2	(4) 3/8	(3) 3/8
EC-1024	30.22						20.12		28.38									
EC-1036	42.22						32.12		40.38									
EC-1054	60.22						50.12		58.32									
EC-1224	30.72	7.75 DIA.	8.75	9.38	4.50	6.25 DIA.	18.97	5.87	27.84	1.43	5.00	6.25	2	#32 SAE	3	(4) 3/8		
EC-1236	42.72						30.97		39.84									
EC-1254	60.72						48.97		57.84									
EC-1272	78.72						66.97		75.84									
EC-1724	32.22	10.50 DIA.	11.50	12.50	5.75	8.50 DIA.	18.75	7.23	29.25	1.99	7.00	8.25	.62 x .88 SLOT	3	N/A	4	(3) 3/8	
EC-1736	45.22						30.75		41.25									
EC-1754	63.22						48.75		59.25									
EC-1772	81.22						66.75		77.25									
EC-1784	43.22						78.75		89.25									

NOTE: We reserve the right to make reasonable design changes without notice. All dimensions are in inches.

# DIMENSIONS

## TWO PASS

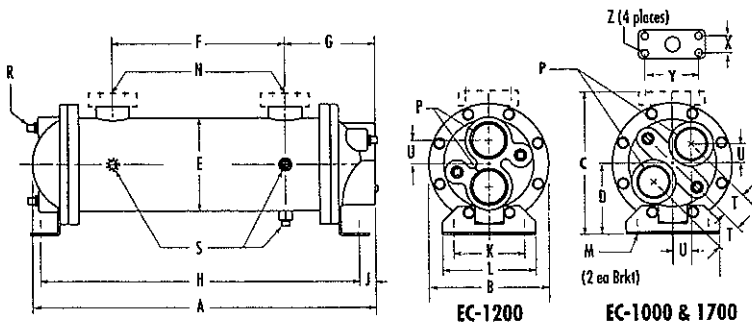

SAE Flange Size	X	Y	Z
1-1/2	1.41	2.75	1/2 - 13
2	1.69	3.06	UNC-2B
3	2.44	4.19	5/8 - 11 UNC 2B

MODEL	A	B	C		D	E	F	G	H	J	K	L	M	N		P	R	S	T	U
			NPT / BSPP SAE O-RING	SAE FLANGE										NPT / BSPP FLANGE	SAE O-RING					
EC-1014	19.75	6.75 DIA.	7.75	8.00	4.00	5.25 DIA.	10.12	5.05	18.38	.92	4.00	5.25	.50 x .75 SLOT	1-1/2	#24 SAE	1-1/2	(4) 3/8	3/8	1.50	1.06
EC-1024	29.75						20.12		28.38											
EC-1036	41.75						32.12		40.38											
EC-1054	59.75						50.12		58.32											
EC-1224	29.75	7.75 DIA.	8.75	9.38	4.50	6.25 DIA.	18.97	5.44	27.84	1.00	5.00	6.25	2	#32 SAE	2	(4) 3/8	3/8	—	1.56	
EC-1236	41.75						30.97		39.84											
EC-1254	59.75						48.97		57.84											
EC-1272	77.75						66.97		75.84											
EC-1724	32.37	10.50 DIA.	11.50	12.50	5.75	8.50 DIA.	18.75	7.06	29.25	1.81	7.00	8.25	.62 x .88 SLOT	3	N/A	4	3/8	2.25	1.59	
EC-1736	44.37						30.75		41.25											
EC-1754	62.37						48.75		59.25											
EC-1772	80.37						66.75		77.25											
EC-1784	92.37						78.75		89.25											

NOTE: We reserve the right to make reasonable design changes without notice. All dimensions are in inches.

# DIMENSIONS

## FOUR PASS

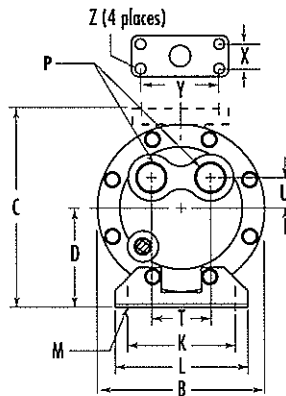
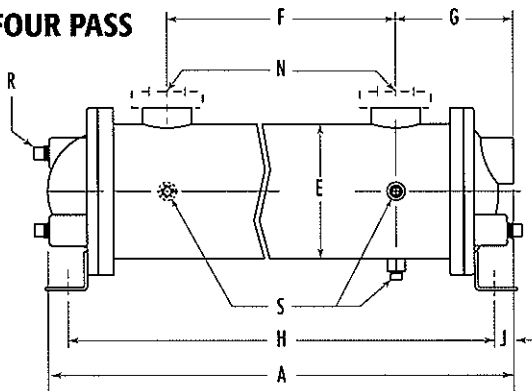

SAE FLANGE SIZE	X	Y	Z
1-1/2	1.41	2.75	1/2 - 13 UNC-2B
2	1.69	3.06	
3	2.44	4.19	5/8 - 11 UNC-2B

MODEL	A	B	C NPT BSPP SAE O-RING	SAE FLANGE	D	E	F	G	H	J	K	L	M	N NPT BSPP FLANGE	SAE O-RING	P NPT BSPP	R NPT BSPP	S NPT BSPP	T	U	
EC-1014	19.87	6.75 DIA.	7.75	8.00	4.00	5.25 DIA.	10.12	4.82	18.38	.75	4.00	5.25	.50 x .75 SLOT	1 1/2	#24 SAE	1			2.40	1.20	
EC-1024	29.87						20.12														28.38
EC-1036	41.87						32.12														40.38
EC-1054	59.87						50.12														58.38
EC-1224	29.78	7.75 DIA.	8.75	9.38	4.50	6.25 DIA.	18.97	5.44	27.84	1.00	5.00	6.25	.50 x .75 SLOT	2	#32 SAE	1 1/2	(3) 3/8	(3) 3/8	2.82	1.41	
EC-1236	41.78						30.97														39.84
EC-1254	59.78						48.97														57.84
EC-1272	77.78						66.97														75.84
EC-1724	31.61	10.50 DIA.	11.50	12.50	5.75	8.50 DIA.	18.75	7.06	29.25	1.81	7.00	8.25	.62 x .88 SLOT	3	N/A	2			4.25	1.41	
EC-1736	43.61						30.75														41.25
EC-1754	61.61						48.75														59.25
EC-1772	79.61						66.75														77.25
EC-1784	91.61					78.75		89.25													

NOTE: We reserve the right to make reasonable design changes without notice. All dimensions are in inches.

## SELECTION PROCEDURE

Performance Curves are based on 100SSU oil leaving the cooler 40°F higher than the ambient air temperature used for cooling. This is also referred to as a 40°F approach temperature.

### Step 1. Determine the Heat Load.

This will vary with different systems, but typically coolers are sized to remove 25 to 50% of the input nameplate horsepower. (Example: 100 HP Power Unit x .33 = 33 HP Heat load.)

If BTU/Hr. is known:  $HP = \frac{BTU/Hr}{2545}$

### Step 2. Determine Approach Temperature.

Desired oil leaving cooler °F - Water inlet temp. °F = Actual Approach (Max. reservoir temp.)

### Step 3. Determine Curve Horsepower Heat Load.

Enter the information from above:

Horsepower heat load x  $\frac{40}{\text{Actual Approach}}$  x Viscosity Correction A = Curve Horsepower

### Step 4. Enter curves at oil flow through cooler and curve horsepower.

Any curve above the intersecting point will work.

### Step 5. Determine Oil Pressure Drop from Curves:

● = 5 PSI; ■ = 10 PSI; ▲ = 20 PSI. Multiply pressure drop from curve by correction factor found in oil ΔP correction curve.

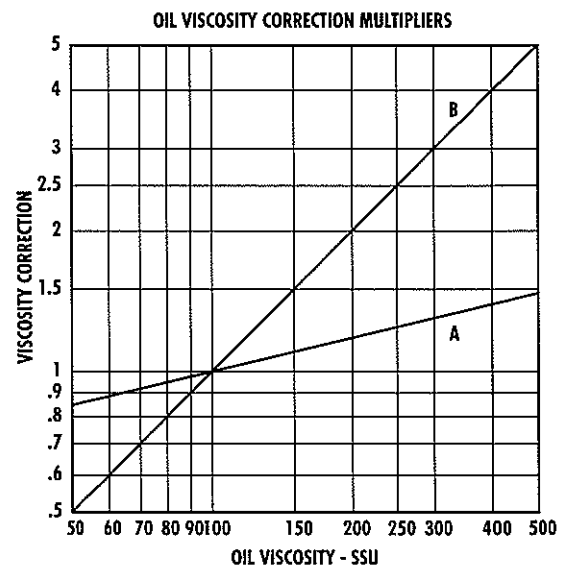

# PERFORMANCE CURVES

## 1:1 Oil to Water Ratio - HIGH WATER USAGE

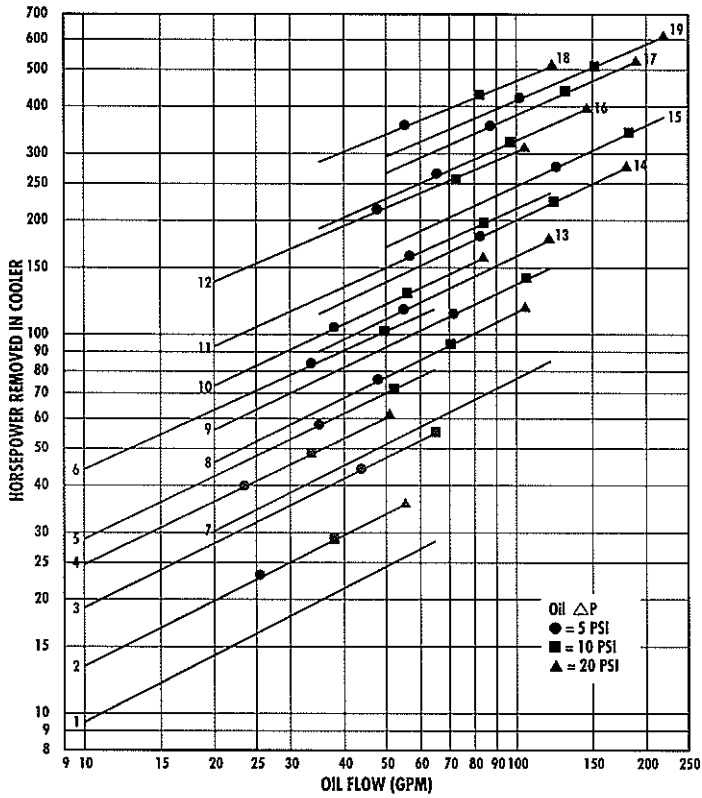

MODELS	NET	WEIGHTS (LBS.) APPROX. SHIPPING
1. EC-1014-7-0	28	32
2. EC-1014-4-0	28	32
3. EC-1024-6-0	45	50
4. EC-1024-4-0	45	50
5. EC-1036-6-0	66	70
6. EC-1054-7-0	105	140
7. EC-1224-12-0	98	105
8. EC-1224-6-0	98	105
9. EC-1236-9-0	125	145
10. EC-1236-6-0	125	145
11. EC-1254-9-0	155	180
12. EC-1272-9-0	210	250
13. EC-1724-6-0	145	175
14. EC-1736-9-0	201	235
15. EC-1754-14-0	275	305
16. EC-1754-9-0	275	305
17. EC-1772-12-0	330	380
18. EC-1772-9-0	330	380
19. EC-1784-14-0	390	450

NET	WEIGHTS (LBS.) APPROX. SHIPPING
28	32
28	32
45	50
45	50
66	70
105	140
98	105
98	105
125	145
125	145
155	180
210	250
145	175
201	235
275	305
275	305
330	380
330	380
390	450

water cooled  
EK/K/EC/EKT

# PERFORMANCE CURVES

## 2:1 Oil to Water Ratio - MEDIUM WATER USAGE

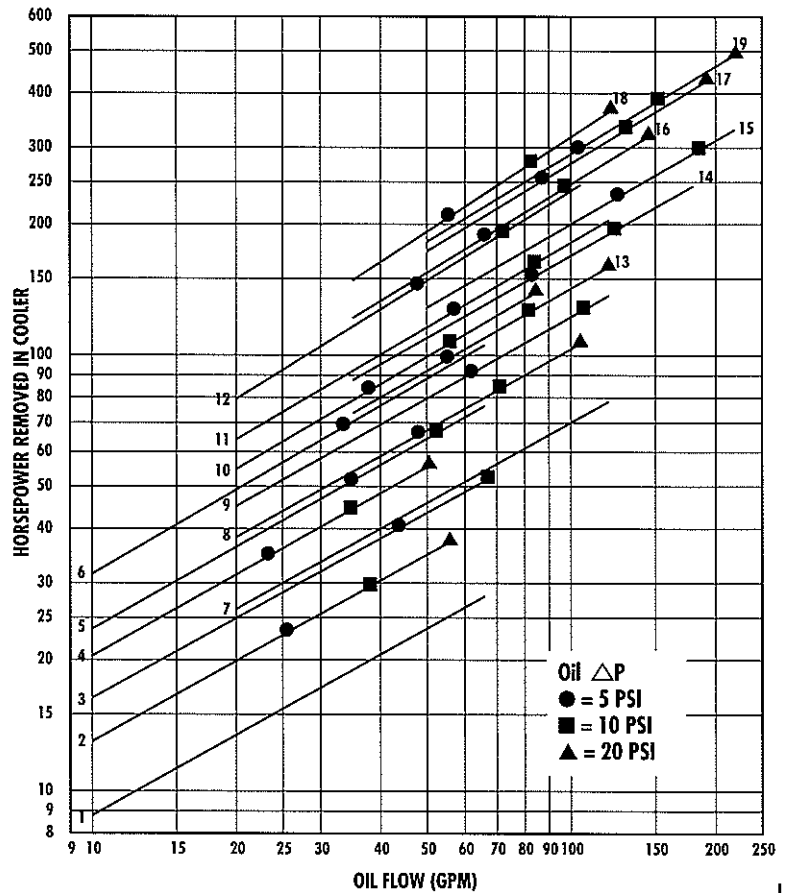

MODELS	NET	WEIGHTS (LBS.) APPROX. SHIPPING
1. EC-1014-7-T	28	32
2. EC-1014-4-T	28	32
3. EC-1024-6-T	45	50
4. EC-1024-4-T	45	50
5. EC-1036-6-T	66	70
6. EC-1054-7-T	105	140
7. EC-1224-12-T	98	105
8. EC-1224-6-T	98	105
9. EC-1236-9-T	125	145
10. EC-1236-6-T	125	145
11. EC-1254-9-T	155	185
12. EC-1272-9-T	210	250
13. EC-1724-6-T	145	175
14. EC-1736-9-T	201	235
15. EC-1754-14-T	275	305
16. EC-1754-9-T	275	305
17. EC-1772-12-T	330	380
18. EC-1772-9-T	330	380
19. EC-1784-14-T	390	450

# PERFORMANCE CURVES

## 4:1 Oil to Water Ratio - LOW WATER USAGE

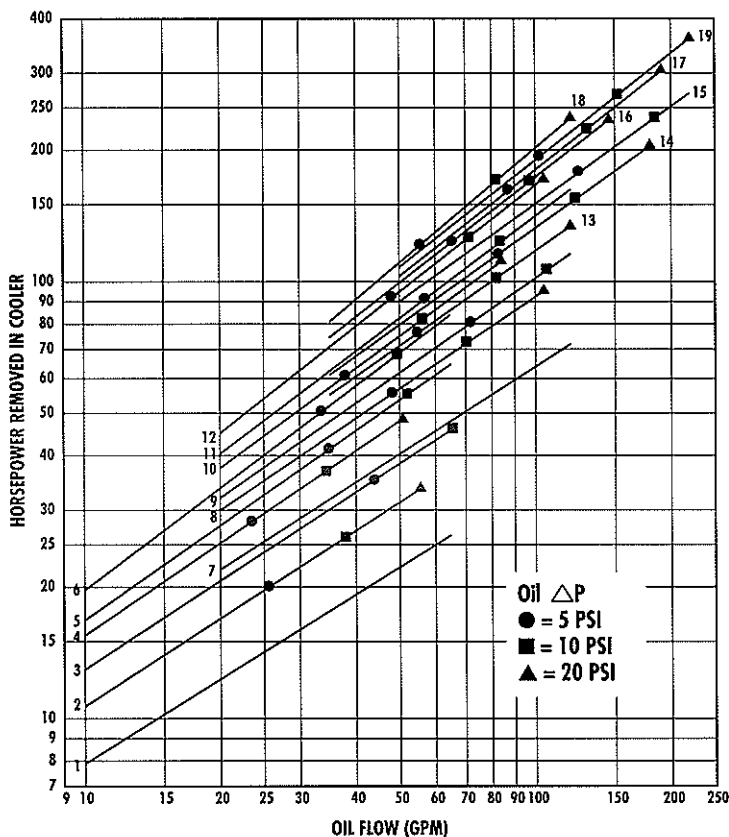

**MODELS**

1. EC-1014-7-F
2. EC-1014-4-F
3. EC-1024-6-F
4. EC-1024-4-F
5. EC-1036-6-F
6. EC-1054-7-F
7. EC-1224-12-F
8. EC-1224-6-F
9. EC-1236-9-F
10. EC-1236-6-F
11. EC-1254-9-F
12. EC-1272-9-F
13. EC-1724-6-F
14. EC-1736-9-F
15. EC-1754-14-F
16. EC-1754-9-F
17. EC-1772-12-F
18. EC-1772-9-F
19. EC-1784-14-F

**NET**

- 28  
28  
45  
45  
66  
105  
98  
98  
125  
125  
155  
210  
145  
201  
275  
275  
330  
330  
390

**WEIGHTS (LBS.) APPROX. SHIPPING**

- 32  
32  
50  
50  
70  
140  
105  
105  
145  
145  
180  
250  
175  
235  
305  
305  
380  
380  
450

# PERFORMANCE CURVES

## 7:1 Oil to Water Ratio - LOWER WATER USAGE

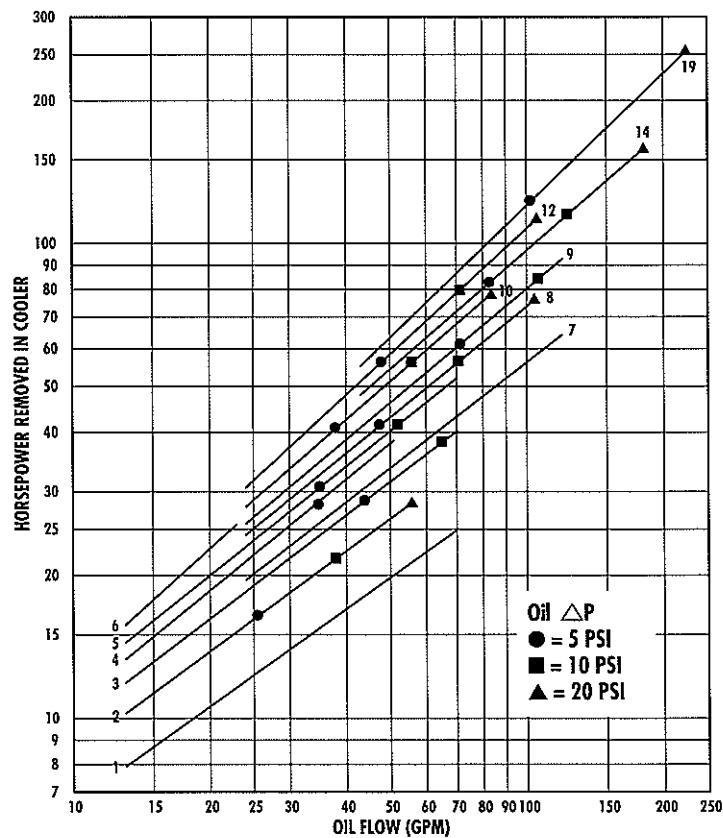

**MODELS**

1. EC-1014-7-F
2. EC-1014-4-F
3. EC-1024-6-F
4. EC-1024-4-F
5. EC-1036-6-F
6. EC-1054-7-F
7. EC-1224-12-F
8. EC-1224-6-F
9. EC-1236-9-F
10. EC-1236-6-F
12. EC-1254-9-F
14. EC-1736-9-F
19. EC-1784-14-F

**NET**

- 28  
28  
45  
45  
66  
105  
98  
98  
125  
125  
210  
201  
390

**WEIGHTS (LBS.) APPROX. SHIPPING**

- 32  
32  
50  
50  
70  
140  
105  
105  
145  
145  
250  
235  
450



# PERFORMANCE CURVES

## 10:1 Oil to Water Ratio - LOWEST WATER USAGE

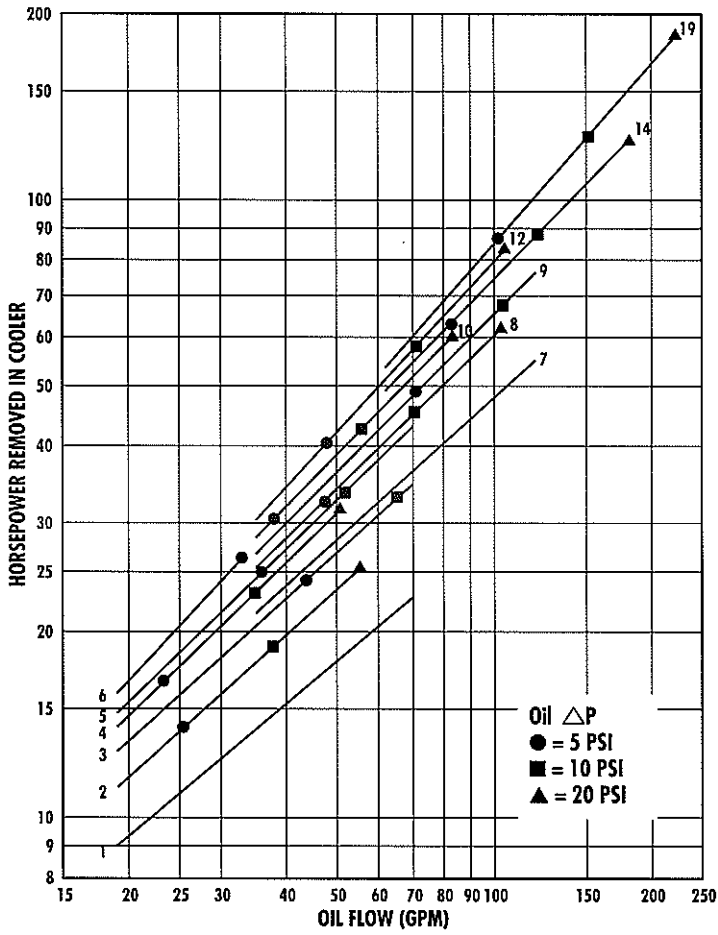

MODELS	NET	APPROX. SHIPPING
1. EC-1014-7-F	28	32
2. EC-1014-4-F	28	32
3. EC-1014-6-F	45	50
4. EC-1024-4-F	45	50
5. EC-1036-6-F	66	70
6. EC-1054-7-F	105	140
7. EC-1224-12-F	98	105
8. EC-1224-6-F	98	105
9. EC-1236-9-F	125	145
10. EC-1236-6-F	125	145
12. EC-1254-9-F	210	250
14. EC-1736-9-F	201	235
19. EC-1784-14-F	390	450

WEIGHTS (LBS.)	NET	APPROX. SHIPPING
28	32	
45	50	
66	70	
105	140	
98	105	
98	105	
125	145	
125	145	
210	250	
201	235	
390	450	

water cooled  
EK/K/EC/EKT

# WATER COOLED INDUSTRIAL/EKT SERIES

**COMPACT SIZE**

**HIGH EFFICIENCY FINNED BUNDLE DESIGN**

**SERVICEABLE**

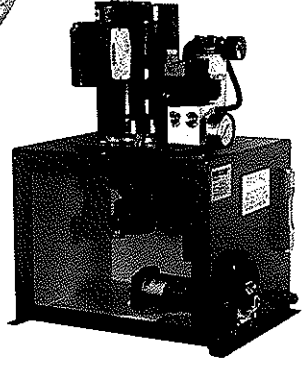
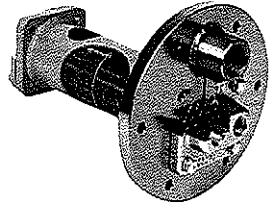

- In-tank Design Minimizes Space Requirements and Reduces Plumbing
- Internal Aluminum Fins Dramatically Increase Performance
- Removable End Bonnets Allow Water Passage Servicing
- High Strength Steel Shell

**OPTIONS:**  
SAE or BSPP Connections Available  
Internal Oil Flow Bypass Relief (Surge-Cushion®)

## MATERIALS

**Shell** - Steel  
**Tubes** - Copper  
**Fins** - Aluminum  
 **Tubesheets** - Steel

**Baffles** - Steel  
**End Bonnets** - Cast Iron  
**Gaskets** - Nitrile Rubber/Cellulose Fiber

## RATINGS

**Operating pressure** - psi  
**Shellside** - 75 /  **Tubeside** - 150  
**Test pressure** - psi  
**Shellside** - 75 /  **Tubeside** - 150  
**Maximum temperature** - 250°F

## SURGE-CUSHION (Option)

The SURGE-CUSHION® is a protective device (patented) designed to internally bypass a portion of the oil flow during cold start conditions, or when sudden flow surges temporarily exceed the maximum flow allowed for a given cooler. This device may replace an external bypass valve, but it is not intended to bypass the total oil flow.

## MAXIMUM FLOW RATES

MODEL SIZE	SHELL SIDE GPM	TUBE SIDE GPM
500	20	6
700	60	12
1000	80	28

If maximum allowable flow rates are exceeded, premature failure may occur.

## HOW TO ORDER

<input type="checkbox"/>	-	<input type="checkbox"/>	-	<input type="checkbox"/>
<b>MODEL SERIES</b>		<b>UNIT SIZE SELECTED</b>		<b>SURGE-CUSHION®</b>
EKT - NPT CONNECTIONS EKTS - SAE OIL CONNECTIONS EKTM - ALL METRIC CONNECTIONS				BLANK - NO SURGE-CUSHION® R - SURGE-CUSHION®

# PERFORMANCE CURVES

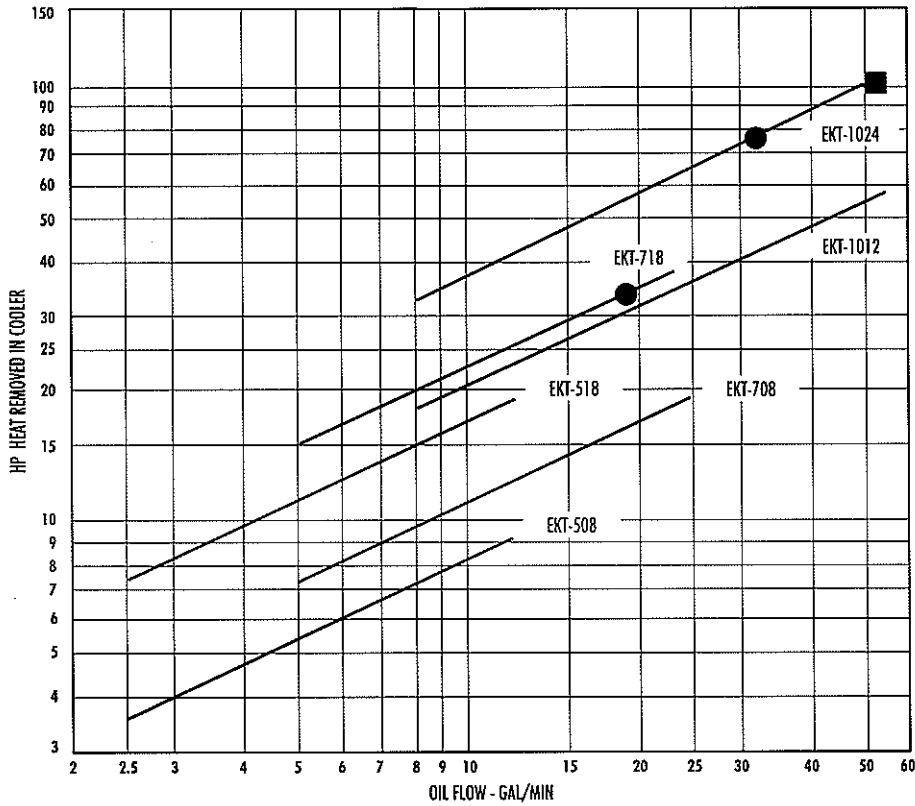

## SELECTION PROCEDURE

Performance Curves are based on a 40°F approach temperature, a 2:1 oil to water ratio and an average oil viscosity of 100 SSU. Example: oil leaving cooler at 125°F with 85°F cooling water (125°F - 85°F = 40°F). The 2:1 oil to water ratio means that for every GPM of oil circulated, a minimum of 1/2 GPM of water must be circulated to obtain the curve results.

### Step 1. Corrections for approach temperature and oil viscosity.

$$HP_{\text{Heat Removed in Cooler}} = HP_{\text{Actual}} \times \left\{ \frac{40^\circ\text{F}}{\text{Oil out and } ^\circ\text{F} - \text{Water in } ^\circ\text{F}} \right\} \times \text{Correction A}$$

### Step 2. Oil Pressure Drop Coding:

● = 5 PSI; ■ = 10 PSI. Curves having no pressure drop symbol indicate that the oil pressure drop is less than 5 PSI to the highest oil flow rate for that curve. Multiply curve oil pressure drop by Correction B.

## VISCOSITY CORRECTIONS

Average Oil SSU	A	B
50	0.84	0.6
100	1.0	1.0
200	1.14	2.0
300	1.24	3.1
400	1.31	4.1
500	1.37	5.1

## DIMENSIONS

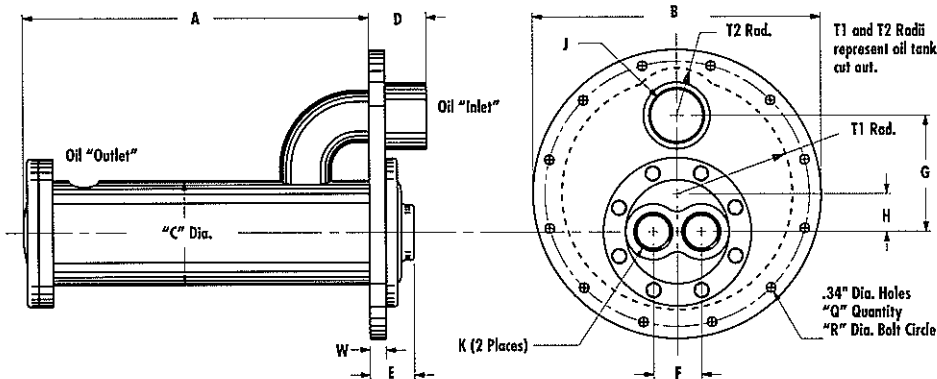

For more information or to purchase these products, please contact:

**HYDROTHRIFT CORPORATION**  
**(800) 772-0493**

[www.hydrothrift.com](http://www.hydrothrift.com)  
[sales@hydrothrift.com](mailto:sales@hydrothrift.com)

MODEL	A	B	C	D	E	F	G	H	J NPT or BSPP	J SAC	K NPT or BSPP	Q	R	T1	T2	W	Net. Wt.	Approx. Ship Wt.
EKT-508	8.87	-	-	-	-	-	-	-	-	-	-	-	-	-	-	-	11	14
EKT-518	18.87	6.79	2.55	1.84	1.68	1.12	2.44	.50	3/4"	#12	3/8"	6	5.60	2.25	.79	.62	14	16
EKT-708	8.72	-	-	-	-	-	-	-	-	-	-	-	-	-	-	-	23	27
EKT-718	18.72	9.75	3.52	-	1.67	1.62	3.94	1.25	-	-	3/4"	12	8.94	4.00	-	.70	30	34
EKT-1012	12.55	10.38	5.05	2.22	2.23	2.38	4.69	1.19	1-1/2"	#24	1"	12	9.62	4.38	1.12	.70	42	46
EKT-1024	24.55	-	-	-	-	-	-	-	-	-	-	-	-	-	-	-	58	63

NOTE: We reserve the right to make reasonable design changes without notice. Certified drawings are available upon request. All dimensions are in inches. Tank gasket is included. BSPP threads are 55° full form whitworth.